



# *Flamcomat G4*

## *Flamcomat Starter G4*



**ENG** Installation and operating instruction

Download the Flamco app for Apple or Android.



**Content**

- 1. Liability ..... 6**
- 2. Warranty ..... 6**
- 3. Copyright ..... 6**
- 4. General safety instructions ..... 6**
  - Definitions ..... 6
  - 4.1 Warning symbols in this manual ..... 7**
  - 4.2 Purpose and use of this manual ..... 7**
    - Such services include: ..... 7
  - 4.3 Qualifications required, assumptions ..... 8**
  - 4.4 Staff qualification ..... 8**
  - 4.5 Appropriate use ..... 9**
  - 4.6 Incoming goods ..... 9**
  - 4.7 Transportation, storage, unpacking ..... 9**
  - 4.8 Operations room ..... 10**
  - 4.9 Noise reduction ..... 11**
  - 4.10 EMERGENCY-STOP / EMERGENCY-OFF ..... 11**
  - 4.11 Personal protective equipment (PPE) ..... 11**
  - 4.12 Exceeding permitted pressure / temperature levels ..... 11**
  - 4.13 System water ..... 12**
  - 4.14 Safeguards ..... 12**
    - Mechanical hazards: ..... 12
    - Electrical hazards: ..... 12
  - 4.15 External forces ..... 12**
  - 4.16 Inspection prior to commissioning, maintenance and re-inspection ..... 13**
    - Tests in line with the German ordinance on operational safety (BetrSichV, June 2015): ..... 13
  - 4.17 Electrical equipment inspections, routine inspection ..... 13**
  - 4.18 Maintenance and repairs ..... 14**
  - 4.19 Obvious misuse ..... 14**
  - 4.20 Other hazards ..... 14**
- 5. Product description ..... 15**
  - 5.1 Operating principle ..... 15**
    - Flamcomat ..... 15
    - Flamcomat starter ..... 16
  - 5.2 Connectivity options ..... 16**
  - 5.3 Markings ..... 17**
  - 5.4 Type key Pump control unit ..... 17**
  - 5.5 Component parts, vessels and connection assembly ..... 18**
  - 5.6 Component parts, pump module ..... 19**
  - 5.7 Control unit ..... 22**
- 6. Assembly ..... 23**
  - 6.1 Setup ..... 23**
  - 6.2 Vessel connection ..... 24**
  - 6.3 Top-up connection ..... 25**
  - 6.4 Drain connection ..... 25**
  - 6.5 System connection ..... 26**
  - 6.6 Electrical Installation ..... 27**

<b>7. Commissioning</b> .....	<b>28</b>
7.1 Initial commissioning.....	28
Commissioning is preferably done via Flamconnect App. ....	28
7.2 Overview menu options .....	29
Commissioning .....	29
7.3 Volume level and operating temperature.....	30
7.4 Clarification of menu icons, function and location .....	31
Operation Screen .....	33
Pressure settings.....	33
Degassing settings .....	33
7.5 Top-up, operation with the water treatment module .....	34
7.6 Malfunction messages.....	34
7.7 Restarting .....	36
After long periods of downtime:.....	36
If the power supply has failed:.....	36
<b>8. Maintenance</b> .....	<b>37</b>
8.1 Vessel draining/refilling. ....	38
<b>9. Decommissioning, dismantling</b> .....	<b>38</b>
<b>Appendix</b>	
<b>Appendix 1.</b> .....	<b>39</b>
<b>Technical data, information</b> .....	<b>39</b>
Ambient conditions.....	39
Minimum distances.....	39
Installation examples.....	40
<b>Appendix 2.</b> .....	<b>41</b>
<b>Technical data, specifications, hydraulic equipment</b> .....	<b>41</b>
Vessels: volume, dimensions and weights.....	41
Vessel: operational characteristics .....	42
Pump module: dimensions and weights .....	42
Control module external pressure retention, operational characteristics .....	43
Control module external pressure retention, manual control valve, adjustment values.....	44
Control module external pressure retention, top-up, flow rate.....	44
<b>Appendix 3.</b> .....	<b>45</b>
<b>Technical data, information, electrical equipment</b> .....	<b>45</b>
Pump unit, nominal values.....	45
Control unit, terminal plans .....	46
Flextronic terminal plan.....	46
Flextronic-400 terminal plan .....	46
<b>EU Declaration of Conformity</b> .....	<b>47</b>

## 1. Liability

All technical specifications, data and instructions for executable actions and actions that must be executed contained herein are correct at time of publication. This information is the result of our current findings and experience to the best of our knowledge. We reserve the right to make technical changes subject to the future development of the Flamco product referred to in this publication. Hence no rights may be derived from technical data, descriptions and illustrations. Technical pictures, drawings and graphs do not necessarily correspond to the actual assemblies or parts as delivered. Drawings and pictures are not to scale and contain symbols for simplification.

## 2. Warranty

You can find the corresponding specifications in our [General Terms and Conditions](#).

## 3. Copyright

This manual must be used confidentially. It may be circulated among authorised personnel only. It must not be given to third parties. All documentation is protected by copyright. Distribution or other forms of reproduction of documents, even extracts, exploitation or notification of the contents hereof is not permitted, where not otherwise specified. Infringements are liable to prosecution and payment of compensation. We reserve the right to exercise all intellectual property rights.

## 4. General safety instructions

Disregard or lack of attention to the information and measures in this manual may pose a hazard to people, animals, the environment and tangible assets. Failure to observe the safety regulations and the neglect of other safety measures may lead to the lapse of liability for damages in the event of damage or loss.

### Definitions

- **Operator:** A natural person or legal entity who is the owner of the product and uses the aforementioned product, or is nominated to use it, under the terms of a contractual agreement.
- **Principal:** The legally and commercially responsible party in the execution of construction projects. Legally and commercially liable client in the commission of building projects.
- **Responsible person:** The representative appointed to act by the main contractor or operator.
- **Qualified person (QP):** Any person whose professional training, experience and recent professional activity gives them the requisite professional knowledge. This implies that said person has knowledge derived from relevant national and internal safety regulations.

## 4.1 Warning symbols in this manual

 **Warning against hazardous electric current.**  
Disregarding this could put lives at risk, cause fires or trigger accidents, lead to component overload and damage, or prevent functionality.

 **Warning against the implications of errors and incorrect set-up conditions.**  
Disregarding this could lead to serious personal injury, to component overload and damage, or prevent functionality.

 **Caution! Dangerously high temperatures.**  
Failure to observe this caution may result in burns to the skin.

 **You are advised to wear eye protection.**  
Failure to observe this advice may result in eye injury.

 **Caution about transporting heavy objects.**  
Failure to observe this caution may endanger the safety of people in the immediate vicinity of the load.

Caution  
Heavy load  
use fork lift

## 4.2 Purpose and use of this manual

The following pages list the information, specifications, measures and technical data that allow the relevant personnel to use this product safely and for the intended purpose.

Responsible persons or those engaged by them carrying out the required services must read this manual attentively and understand it.

### Such services include:

Storage, transportation, installation, electrical installation, commissioning and re-starting, operation, maintenance, inspection, repair and dismantling.

Where the product is to be used in plants/facilities which do not comply with harmonised European regulations and relevant technical rules and guidelines of professional associations for this field of application, the present document is purely for informative and reference purposes.

As this unit may be subject to unlimited inspection at all times, this manual must be kept in the immediate vicinity of the installed unit, at least within the confines of the operations room.

Installation classification 2 according to the Annex R of 60730-1.

### 4.3 Qualifications required, assumptions

All personnel must have the relevant qualifications to carry out the required services and be physically and psychologically capable. The area of responsibility, competence and supervision of personnel is the duty of the Operator.

Required service	Professional group example	Relevant qualifications example
Storage, transportation	Logistics, transport, warehousing	Transport and warehousing specialist
Assembly, disassembly, repairs, maintenance. Re-commissioning after adding or changing components. Inspection.	Installation and building services	HVAC specialist.
First commissioning of configured control unit (generic), re-commissioning after power cut, operation (work on the terminal and Flextronic control unit)		People with operations room clearance with knowledge gleaned from this guide.
Electrical installation	Electrical engineering	Specialist in electrical engineering/ installation
Initial and re-inspection of electrical systems		Qualified person (QP) with certification in Electrical Engineering
Inspection before commissioning and re-inspection of pressure equipment	Installation and building services engineering performed in the context of technical inspection.	Qualified Person (QP)

### 4.4 Staff qualification

Operating instructions are transferred by Flamco representatives or others assigned by them during delivery negotiations or on demand.

Training for the required services, installation, dismantling, commissioning, operation, inspection, maintenance and repair are part of the training / further education for service engineers of the Flamco branch offices or named service contractors.

These training courses cover information on required installation conditions, but not their implementation.

On-site services include transportation, the preparation of an operations room with the requisite foundation engineering to accommodate the system, and the requisite hydraulic and electrical connections, the electrical installation for the power source of the expansion automat and installation of the signal leads for the IT equipment.

## 4.5 Appropriate use

Sealed water-based heating and cooling systems in which temperature-induced changes in the volume of the system water (the heat transferring agent) can be absorbed and the required operating pressure is governed by a separate expansion automat.

Suitable and equipped for the operation in heat generating systems according to EN 12828, EN 12952, EN 12953.

The Principal / Operator will need to consult with a notified body on additional safety measures.

Use in similar systems (e.g. heat transfer systems for process industry or technologically conditioned heat) may require special measures. Please note that the Flamcomat Starter must not be used in systems with mostly stainless-steel piping and not in combination with a vacuum degasser. The complementary documents must be studied.

## 4.6 Incoming goods

The items delivered must be compared against the items listed on the shipping note and inspected for conformity. Unpacking, installation and commissioning may be started only once the product has been checked to conform with the intended use as stated in the order process and contract. Exceeding the permissible operating or design parameters may lead to malfunctioning, component damage and personal injury.

If not in line with conformity or if the delivery is incorrect in another way, the product must not be used.

## 4.7 Transportation, storage, unpacking



Caution  
Heavy forklift  
use fork lift

The equipment is delivered in packaging units in accordance with the contract specifications or the specifications required for certain modes of transport and climate zones. These units meet at least the requirements set out in the Flamco B.V. packaging directives. In accordance with these directives, expansion vessels must be transported horizontally and pump units upright; each packaged on throw-away pallets. If the packaging is suitable for use with hoisting gear, this will be indicated at the designated hoisting points.



**Important note:** Transport the packed goods as close as possible to the envisaged set-up location and make sure there is a horizontal, solid surface on which the goods can stand.



Note: Take all necessary precautions to ensure that the expansion vessel cannot topple over or wobble once it has been unpacked and removed from the pallet.



Suitable lifting lugs are provided for lifting and moving suspended empty vessels prior to installation. Such devices (lifting lugs) must be used in tandem; avoid side-pulling.

Once it has been removed from the pallet and the packaging, the unit must be transferred by pulling it over suitable surfaces. Use methods that prevent uncontrolled falling, sliding or tipping over. The lifting lugs on the pump unit are designed so the unit can be lifted vertically. They may not be subjected to any lateral force.

The goods may also be warehoused in their packaging. Once it has been removed from its packaging, the equipment must be put in position, observing standard safety procedures. Do not stack the equipment.

Use only permitted lifting gear and safe tools and wear the required personal protective equipment.

## 4.8 Operations room

Definition: room which meets the applicable European regulations, European and harmonised standards and relevant technical rules and guidelines of the professional associations for this field of application. For the use of the expansion automat as prescribed in this manual these rooms generally contain equipment for thermal generation and distribution, water heating/cooling and top-up, power source and distribution, such as measuring, control engineering, control technology and IT.

Access for unqualified and untrained persons must be restricted or forbidden.

The set-up location of the expansion automat must ensure that operation, service, maintenance, inspection, repair, installation and dismantling can be carried out unhindered and without danger. The floor of the set-up location for the expansion automat must be such that stability is guaranteed and maintained. Bear in mind that the maximum possible forces can be exerted from the net mass including the water volume. If stability cannot be guaranteed, there is a danger that the vessel will tip over or move and, as a consequence in addition to functional defects may lead to personal injury.

The ambient atmosphere must be free from conductive gases, high concentrations of dust and aggressive vapours. There is the risk of explosion if any combustible gases are present.

In case of function-driven opening of the drain valve on the backflow preventer (optional top-up) or triggering of the relief valve to prevent overloading of the vessel, as well as for potential overflow at the connection in a case of vessel diaphragm damage to compensate for atmospheric pressure, the top-up or process water is drained. Depending on the process, the water temperature can rise to 70 °C and, in the case of improper operation exceed 70 °C. This presents a danger of personal injury through burns and/or scalding.

It is important to ensure that this water can be drained safely, and - to prevent water damage - that there is a safe drain or water collector in the immediate vicinity of the appropriate equipment (groundwater protection: observe additives!).

Flooded equipment must not be operated. If electrical equipment short circuits, persons or other beings in the water will be electrocuted. Furthermore, there is a danger of malfunction and partial or irreparable damage to individual components due to water saturation and corrosion.

## 4.9 Noise reduction

Installations should be constructed with noise-reduction measures in mind. Mechanical vibrations of the assembly (Module framework, pipework) in particular can be dampened by using insulation between contact surfaces.

### 4.10 EMERGENCY-STOP / EMERGENCY-OFF

To conform with directive 2006/42/EG an EMERGENCY-STOP facility is to be made available during installation. Preferably, use a grounded wall socket for the power supply to the unit. The socket must stay accessible. If the unit is directly connected to the power supply, make sure the power supply line is provided with

- a high-sensitivity differential switch (30mA) (residual current device RCD)
- a mains isolator switch with a contact gap of at least 3 mm.

When additional security measures with EMERGENCY-OFF devices are required according to the design and operation of the heat generator, these are to be installed on-site.

### 4.11 Personal protective equipment (PPE)

PPE must be used when carrying out potentially dangerous work and other activities (e.g. welding), in order to prevent or minimise the risk of personal injury if other measures cannot be taken. These must comply with the requirements specified by the main contractor or operator of the operations room or the site in question.

If no requirements are specified, to operate the automat no PPE is required. Minimum requirements are well-fitting clothing and sturdy, closed and skidproof footwear.

Other services require the protective clothing and equipment necessary for the activity in question (e.g. transport and assembly: rugged, close-fitting work clothing, foot protectors [safety shoes with toe caps], head protection [safety helmet], hand protectors [protective gloves]; maintenance, repair and overhaul: rugged, close-fitting work clothing, foot protectors, hand protectors, eye/ face protector [safety goggles]).

### 4.12 Exceeding permitted pressure / temperature levels

Equipment used in combination with the expansion automat must guarantee that the permitted operating temperature and the permitted medium temperature (heat transfer medium) cannot be exceeded. Excess pressure and temperature may lead to component overload, irreparable damage to components, loss of function and, as a result, to severe personal injury and damage to property. Regular checks/inspections of these safeguards must be carried out. Service logs must be kept.

### 4.13 System water

Water which is non-flammable, does not contain solids or long-fibre components and does not present a danger to operations due to its contents, and will not affect or damage the water bearing components (e.g.: pressurised components, the diaphragm, vessel connection) of the expansion automat. Also observe: VDI 2035 - avoidance of damage to warm water heating equipment.

System water containing components are pipelines, hoses connected to the vessel, devices and system connections including valves and fittings, and their casings, sensors, pumps, the vessel itself and the vessel diaphragm. Operation with improper media can lead to impaired function, damage to components and, as a consequence, to serious personal injury and damage.

### 4.14 Safeguards

The equipment supplied is equipped with the required safety devices. To test their effectiveness or restore the set-up conditions, the equipment must first be taken out of service. Taking the system out of service implies that power should be cut and hydraulic connections blocked, to prevent accidental or unintentional re-connection.

#### **Mechanical hazards:**

The fan cover on the pump protects users from personal injury caused by moving parts. Before switching the unit on, make sure that the cover is suitable for this purpose and properly secured.

#### **Electrical hazards:**

The protection class of electrically operated components prevents personal injury by electrocution, which can be fatal. The protection class is usually IP44. The control unit cover, the cover of the pump feed, the threaded cable glands and the valve connector plugs must be inspected for effectiveness prior to commissioning. The installed pressure and volume sensors are operated with protective extra-low voltage.

Avoid welding work on additional equipment which is electrically connected to the control unit. Stray welding current or an improper earth connection could lead to the danger of fire and damage to parts of the unit (e.g. the control unit).

### 4.15 External forces

Avoid any additional forces (e.g.: forces caused by heat expansion, flow oscillations or dead weights on the flow and return lines). These can lead to damage / leaks in water-bearing pipework, loss of stability of the appliance and furthermore to failure connected with substantial material damage and personal injury.

## 4.16 Inspection prior to commissioning, maintenance and re-inspection

They guarantee operational safety and its observance in line with applicable European regulations, European and harmonised standards and additional national regulations of the EU member states for this field of application. The required inspections must be arranged by the owner or operator; an inspection and maintenance log book for scheduling and traceability of measures taken must be kept.

### Tests in line with the German ordinance on operational safety (BetrSichV, June 2015):

Pressure equipment, vessels (§14; 15)					
Category [see appendix II of Directive 2014/68/EU, diagram 2)	Nominal vessel capacity [litres]	Inspection prior to commissioning [§14] inspector	Re-inspection [§15 (5)]		
			Timeframe, maximum period [a] / inspector		
			External inspection	Internal inspection	Strength inspection
II	200- 300 / 3 bar	Qualified Person (QP)	Maximum period not defined. The maximum interval must be established by the Operator on the basis of information provided by the manufacturer coupled with practical experience and chamber load. The inspection may be carried out by a Qualified person.		
III	400- 10000 / 3 bar		No longer applicable [§15 (6)]	5 / QP	10 / QP
				[§15 (10)] In the case of internal inspections the visual inspection may be replaced by similar procedures and in the case of strength tests the static pressure test may be replaced by similar, non-destructive procedures if said tests would not otherwise be possible due to system design or not significant due to the system mode of operation.	
Maintenance of equipment, interior and strength inspection, see maintenance, Ch. 8.					

In other Member States of the EC, the required tests for the pressure equipment in line with directive 2014/68/EU as defined in the national rules must be performed.

## 4.17 Electrical equipment inspections, routine inspection

Without prejudice to the considerations of the insurer/Operator, it is recommended that the electrical equipment of the Flamcomat be inspected and documented together with the heating/cooling unit no less than every 18 months (see also DIN EN 60204-1 2007).

## 4.18 Maintenance and repairs

These services may only be carried out when the system is shut down or if the expansion automat is not required. The pressurisation equipment must be taken out of service and guarded against unintentional re-starting until the maintenance work is finished. Note that the safety circuits and data transmissions made whilst shutting down could trigger the safety chain or lead to false information. Existing instructions for the heating or cooling unit as a whole must be observed. To stop hydraulic components, block the relevant sections and drain them using the safe system water drains through the available drain connections, and relieve the pressure.



**Caution:** The maximum system water temperature in conducting components (vessel, pumps, casings, hoses, pipelines, peripheral equipment) may reach 70 °C and, in the case of improper operation, may exceed that. This presents a danger of burns and/or scalding.



The maximum pressure of system water in conducting components may be equal to the maximum set pressure for the applicable safety valve. Vessel, nominal pressure 3 bar, safety valve max. 3 bar; pump unit nominal pressure 6; 10 or 16 bar:

Safety valve max. 6; 10 or 16 bar. Use of eye/face protectors is required if the eyes or face could be injured by flying parts or spraying fluids.

To stop electrical equipment (control unit, pumps, valves, peripheral equipment), cut power to the control unit. The power supply must remain off for the period of the work.

It is forbidden to alter or use non-original components or replacement parts without authorisation. Such acts may result in serious personal injury and endanger operational safety. They will also render any claim for damages against product liability void.

It is recommended to contact Flamco Customer Service for carrying out these services.

## 4.19 Obvious misuse

- Operation at incorrect voltage and/or frequency.
- Use in inappropriate system designs.
- Use of unpermitted installation materials.

## 4.20 Other hazards

- Overload of construction parts by the presence of unpredictable extreme values.
- Operational continuity at risk in the case of changed, non-permissible ambient conditions.
- Operational continuity at risk in the case of safety-control parts being taken out of service or malfunctioning.

## 5. Product description

The contents of this manual consist of the specifications for a standard execution. Where appropriate, this includes information on options or other configurations. If optional extras are supplied, further documentation will be supplied in addition to this manual.

For installation instructions and further documentation in various languages, visit [www.flamcogroup.com/manuals](http://www.flamcogroup.com/manuals). Further product information can be obtained from the respective Flamco branch office (see [“Contact” on page 45](#)).

### 5.1 Operating principle

#### Flamcomat

##### 1. Cold

The automat contains a small amount of water.  
The automat is still at rest.

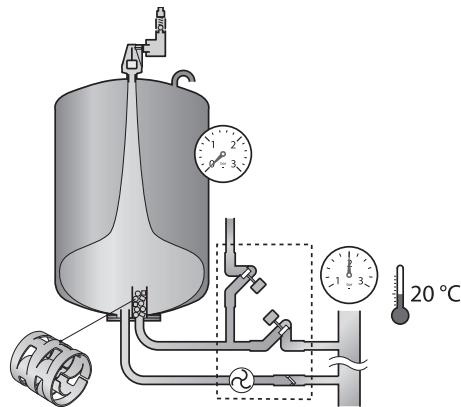

##### 2. Warming up

The volume of water and the system pressure increases. The unit responds to this by opening the solenoid valve. Water flows into the pressureless vessel. The water in the vessel is de-aerated due to both the drop in pressure and the presence of the PALL rings.

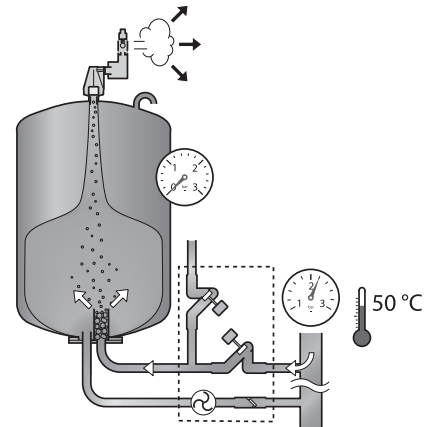

##### 5. Topping-up

If the water level in the vessel drops to a critical level, an appropriate amount of water will be carefully pumped into the system from the water mains. This water will be de-aerated (by pressure loss and the PALL rings), before entering the vessel.

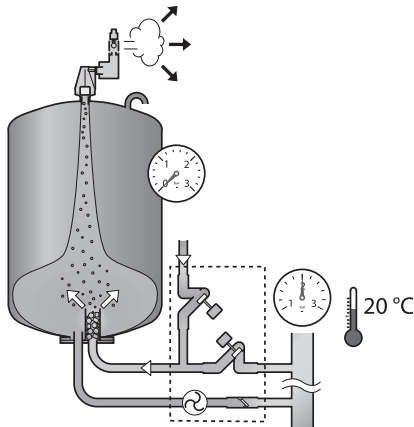

##### 4. Cooling down

The volume of water and the system pressure decreases. The de-aerated water is pumped from the pressureless vessel back into the system. This restores the system pressure.

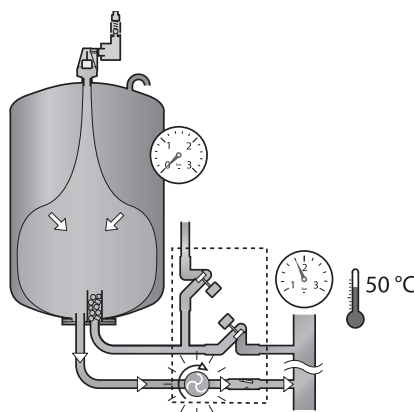

##### 3. Full power

By storing an increasing amount of water in the tank, the automat keeps the system pressure almost constant. When the system has warmed up completely, the vessel will be almost full to capacity.

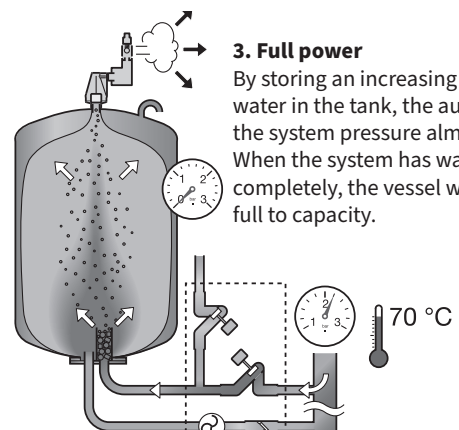

## Flamcomat starter

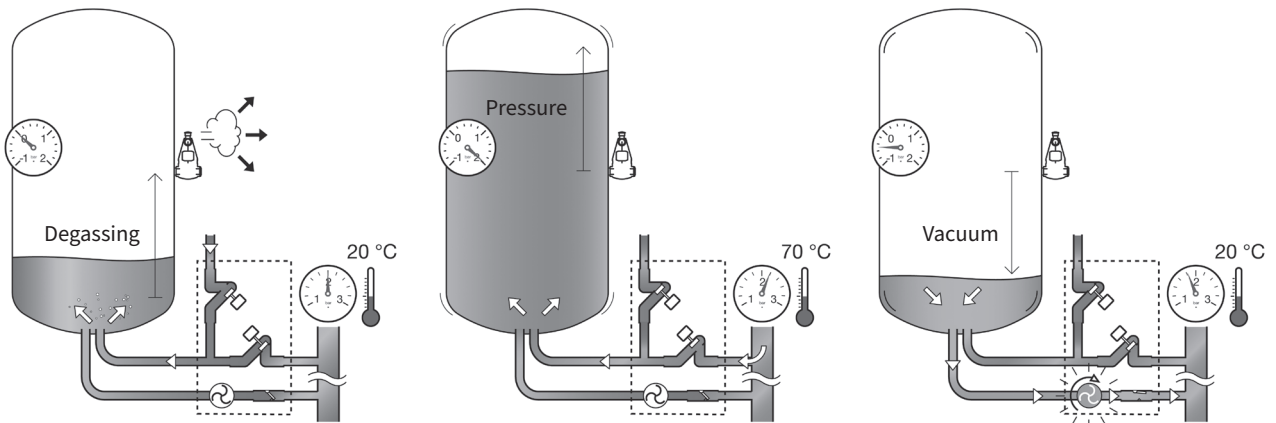

1. Initial filling, refilling and heating

2. Heating up, maximum operation

3. Cooling down, minimum operation

## 5.2 Connectivity options

Connectivity options	Designated use
Ethernet port	To connect Flamcomat to a Building Management System (BMS) via modbus or bacnet.
Standard USB (aka USB-A)	For saving the offline log and the configuration parameters. The second option for this port is to update the firmware of the controller (to download a new control SW)
CAN	This pair of the ports is dedicated for the networking of multiple Flamcomats (master-slave)
RS-485	The primary designation is to connect Flamcomat to Internet (via Gateway and HFC protocol). Alternatively – BMS via Modbus Alternatively – BMS via bacnet (only one out of three options at the same time)
Wireless	To connect a smartphone application

### 5.3 Markings

#### Name plate - Vessel:

Type: _____	
Typ: _____	
N° de série: _____	Année de fabrication: _____
Serial-No.: _____	Year of manufacture: _____
Serien-Nr.: _____	Herstellungsjahr: _____
Capacité nominale: _____ litres	
Nominal volume: _____ litre	
Nenninhalt: _____ Liter	
Surpression de service admissible: _____ bar	
Permissible working overpressure: _____ bar	
Zulässiger Betriebsüberdruck: _____ bar	
Surpression d'essai: _____ bar	
Test overpressure: _____ bar	
Prüfüberdruck: _____ bar	
Température de service mini. / maxi. admissible: _____ °C	
Permissible working temperature min. / max.: _____ °C	
Zulässige Betriebstemperatur min. / max.: _____ °C	
<b>Constructeur: Flamco STAG GmbH</b> <b>Manufacturer: D-39307 Genthin</b> <b>Hersteller: GERMANY</b>	
<b>CE 0045</b>	



#### Name plate - Pump module:

	Typ: _____	Serien-Nr.: _____	Schutzart: _____
	Type: _____	Serial-No.: _____	Protection cl.: _____
	Type: _____	N° de Série: _____	Ci. de protección: _____
		Volgnummer: _____	Beschermingsgr.: _____
Flamco B.V. - Amersfoortseweg 9 - 3751 LJ Bunschoten - the Netherlands			
Nennspannung: _____		Zulässige Medientemperatur min. / max.: _____ °C	
Nominal voltage: _____		Permissible media temperature min. / max.: _____ °C	
Tension nominale: _____		Température de média mini. / maxi. admissible: _____	
Nominale spanning: _____		Toegestane temperatuur media: _____	
Nennstrom: _____ A	Zulässiger Betriebsüberdruck: _____ bar	Herstellungsjahr: _____	
Nominal current: _____	Permissible working overpressure: _____ bar	Year of manufacture: _____	
Courant nominal: _____	Surpression de service admissible: _____ bar	Année de fabrication: _____	
Nominale stroom: _____	Toeslaerbare werkdruk: _____	Jaar van vervaardiging: _____	
Nennleistung: _____ kW	Zulässige Umgebungstemperatur min. / max.: _____ °C		
Nominal power: _____	Permissible ambient temperature min. / max.: _____ °C		
Puissance assignée: _____	Température de ambiante mini. / maxi. admissible: _____		
Nominale vermogen: _____	Toeslaerbare omgevingstemperatuur min. / max.: _____		

#### Electrical warnings:

Attention, high voltage! Opening by qualified personnel only.  
Disconnect the unit from the power supply before opening it.

Achtung, gefährliche Spannung! Nur vom Fachpersonal zu öffnen.  
Vor dem Öffnen des Gerätes spannungsfrei schalten.

	Your reliable partner
Capacity / Inhalt / Inhoud / Contenance: _____	litres
Gas charge / Vordruck / Voordruk / Pression initiale: _____	bar
Max. working pressure / Max. zul. Betriebsüberdruck / Max. werkdruk / Pression de service max.: _____	bar
Test pressure / Prüfdruck / Testdruk / Pression d'épreuve: _____	bar
Max. temp. diaphragm / Max. Betriebstemp. Membrane / Max. temp. membraan / Temp. membrane max.: _____	°C
Min. working temperature / Min. Betriebstemperatur / Min. werkteemperatuur / Température de service min.: _____	°C
Article code / Artikelnummer / Artikelnummer / Code article: _____	
Flamco B.V. - Bunschoten - the Netherlands www.flamcogroup.com	
<b>CE 0038</b>	

#### Transport lock:

Nach Montage:  
Transportsicherung entfernen.

After mounting:  
Remove the transport safety.

Après l'installation:  
Retirez la sécurité des transports.

Na montage:  
Verwijder de veiligheid van het vervoer.

#### Service:

**Service Nederland**  
Tel.: +31(0)33 299 7500  
Fax.: +31(0)33 298 6445

**Service Germany**  
Tel.: +49(0)170 630 40 34

### 5.4 Type key Pump control unit

E.g.: DP80 - 1 - 50

- Nom. frequency of the operating voltage (Hz): 50 = 50 Hz; 60 = 60 Hz
- Pump manufacturer: 1; 2; 3; 4; 5
- Performance class: M;2; 10; 20; 60; 80; 90; 100; 130
- Module version: MP = Monopump; DP = Duopump

## 5.5 Component parts, vessels and connection assembly

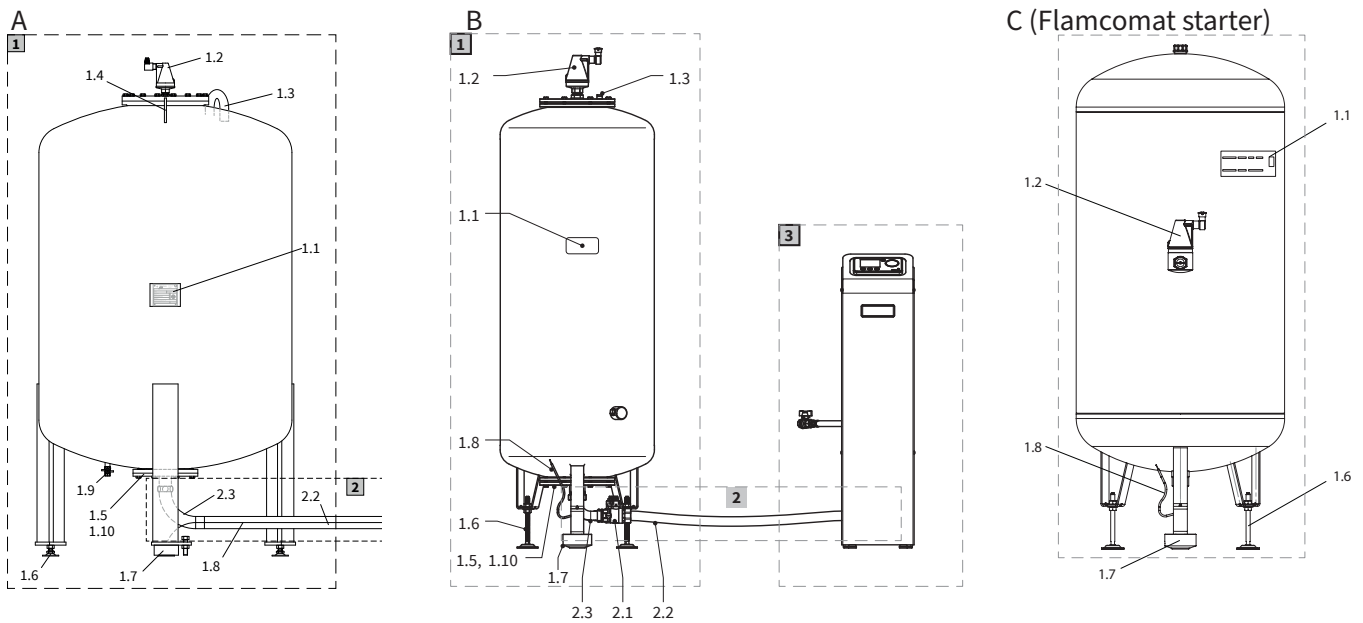

- 1 Basic steel vessel (1A/B with built-in, exchangeable butyl-rubber diaphragm for absorption of the expansion water under atmospheric separation conditions).**
  - 1.1 Name plate - Vessel:
  - 1.2 Bleeder valve, float vent with air-intake preventer to dissipate extracted gases into the atmosphere  
\* Incl. Vacuum safety valve
  - 1.3 Atmospheric pressure balancing connection  
Interior of vessel (space between inner vessel surface and outer diaphragm surface)
  - 1.4 Lifting hook, load suspension for transport
  - 1.5 Flange, vessel connection with internally fitted degassing equipment, screw union, connection array valve outflow line and pump suction line, each with flat gasket (labelling)
  - 1.6 Adjustable feet.
  - 1.7 Capacity sensor with screw-type round plug connector to signal wire
  - 1.8 Signal wire level sensor
  - 1.9 Lockshield valve for condensate drainage
  - 1.10 Markings for pump and valve connection
- 2 Connection assembly, pre-installed, including flat seal**
  - 2.1 Self-draining lockshield valve (vessel) with flat seal, control unit port
  - 2.2 Flexible pressure/suction hose
  - 2.3 Pipe bend, flat sealing, vessel connector (DN32: 400 - 1000 liter, DN40: 1200 - 1600 liter.)
- 3**



## 5.6 Component parts, pump module

### 3 Pump module, control module, including type plate

- 3.1 Pump pressure pipe, system supply (marking)
- 3.2 Pressure sensor
- 3.3 Pump 1 with manual de-aeration (hex screw with seal)
- 3.4 Pump 2 with manual de-aeration (hex screw with seal)
- 3.5 Pump 1, wet runner, self-priming  
A speed select switch, *max. position!*  
B Vent (slotted-head screw with seal)
- 3.6 Pump 2, wet runner, self-priming  
A speed select switch, *max. position!*  
B Vent (slotted-head screw with seal)
- 3.7 Valve discharge pipe, system discharge (marking)
- 3.8 Particle filter
- 3.9 Non-return valve

- 3.10 Manual regulated valve 1 (diagram)
- 3.11 Manual regulated valve 2 (diagram)
- 3.12 Solenoid valve, overflow valve no. 1
- 3.13 Solenoid valve, overflow valve no. 2
- 3.14 Top-up line, incorporating the shut-off valve (lockshield valve), flexible pressure hose, solenoid valve, top-up valve, no. 3, and check valve (optional)
- 3.16 Safety valve (vessel)
- 3.17 Lockshield valve system connection (optional)
- 3.18 Automatic deaerator with air-intake preventer (MP,DP60-1 -50)
- 3.19 Control unit, Flextronic
- 3.20 Bleed pump
- 3.21 Manual regulated valve 3 (diagram)
- 3.22 Front panel
- 3.23 Control unit, Flextronic 400V

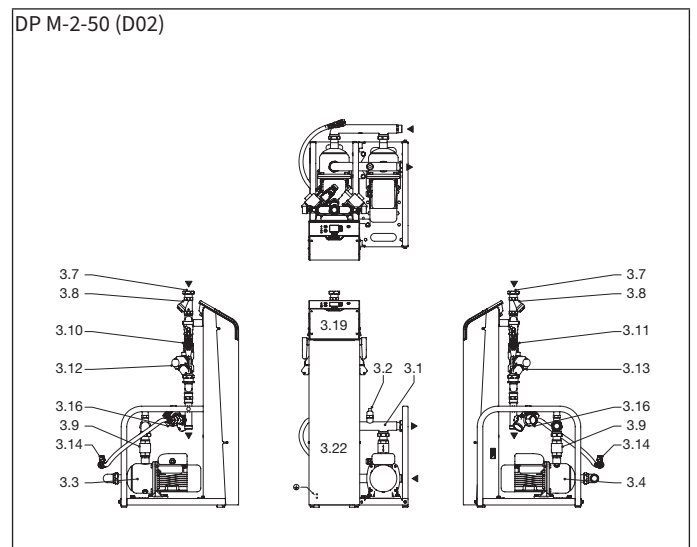
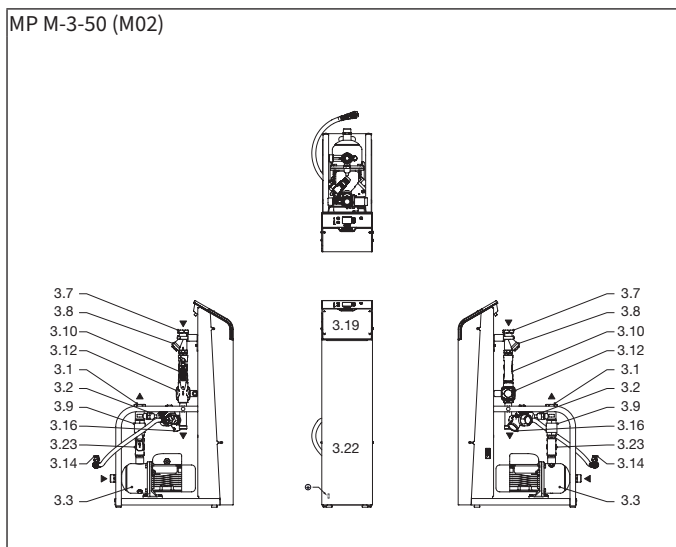
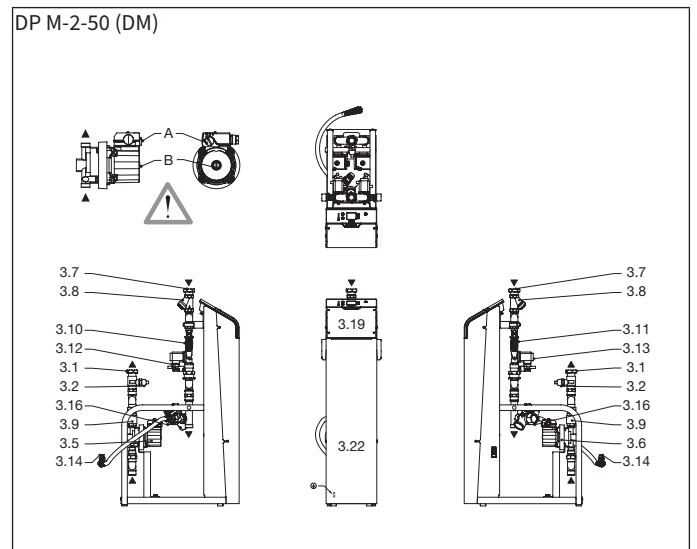
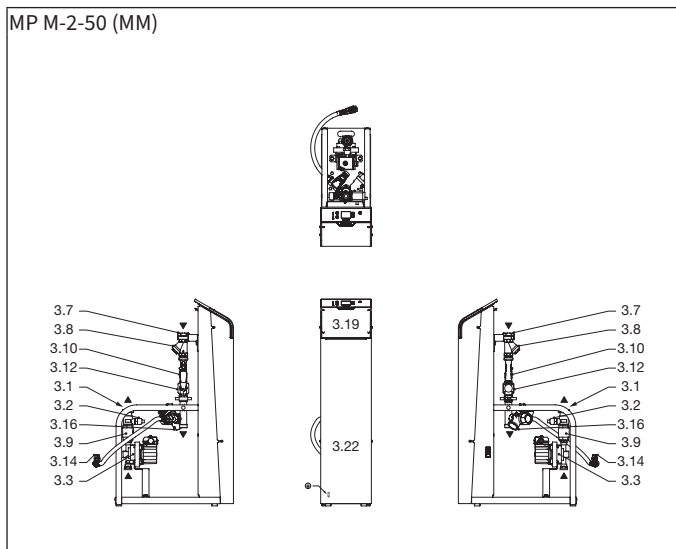

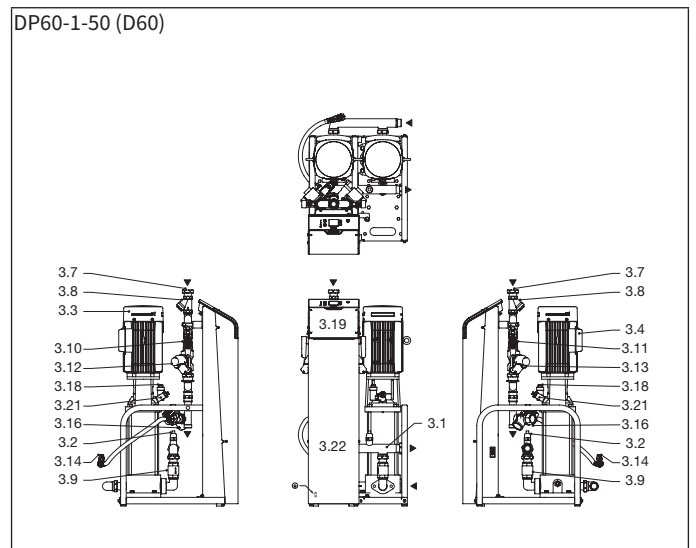
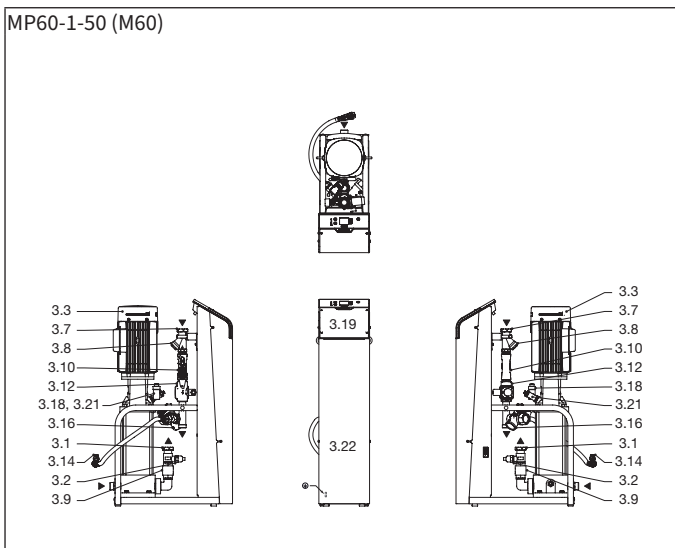
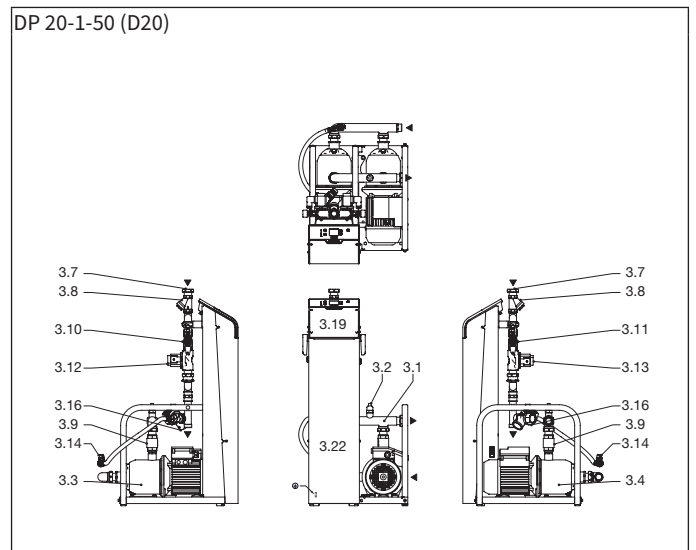
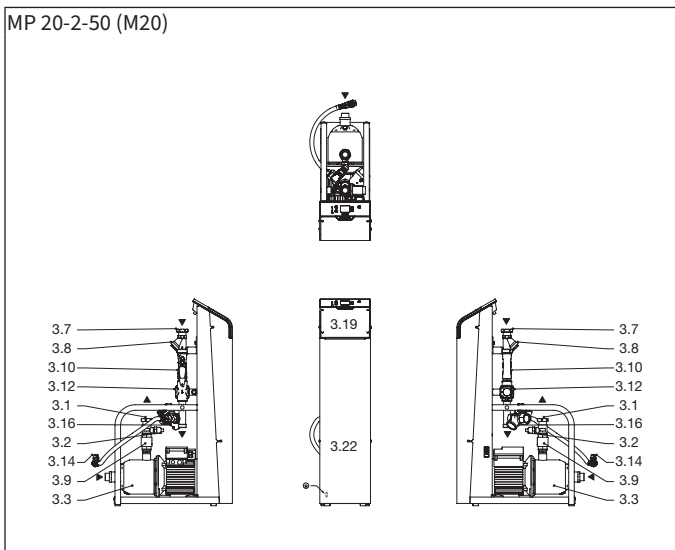
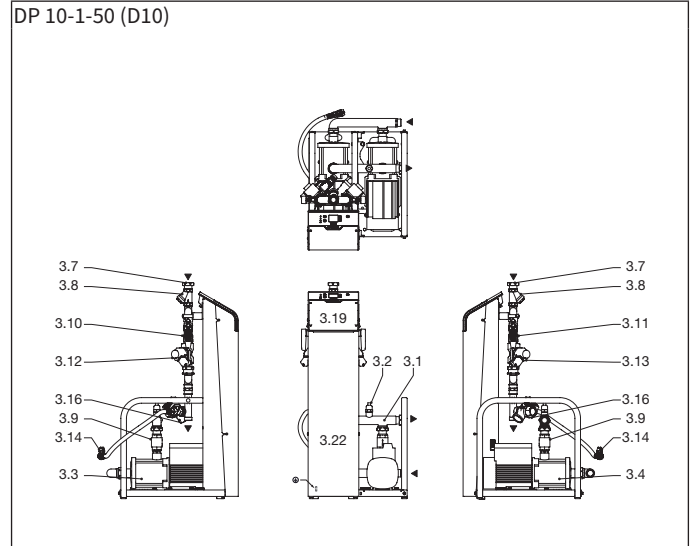
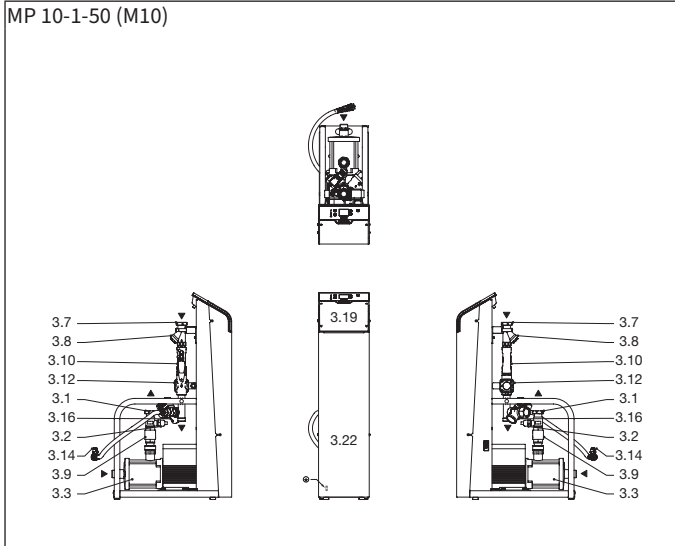

For item designations, [“5.6 Component parts, pump module” on page 19.](#)

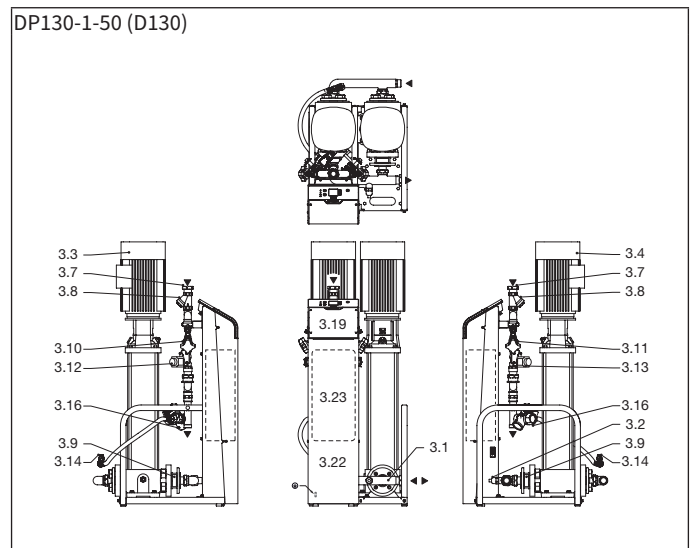
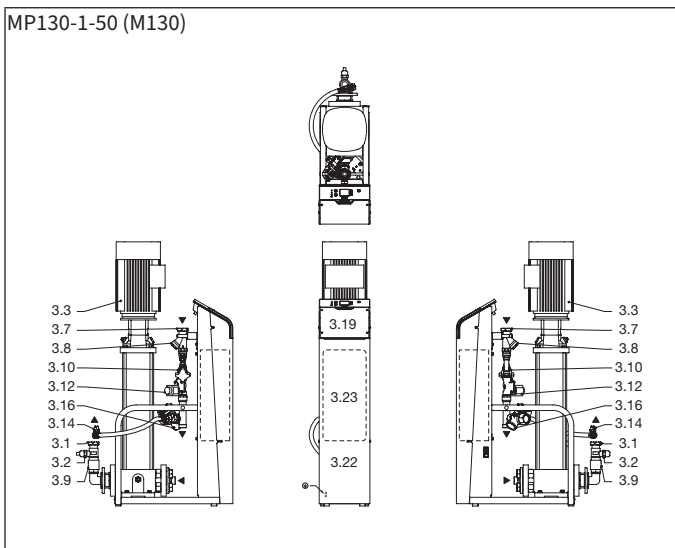
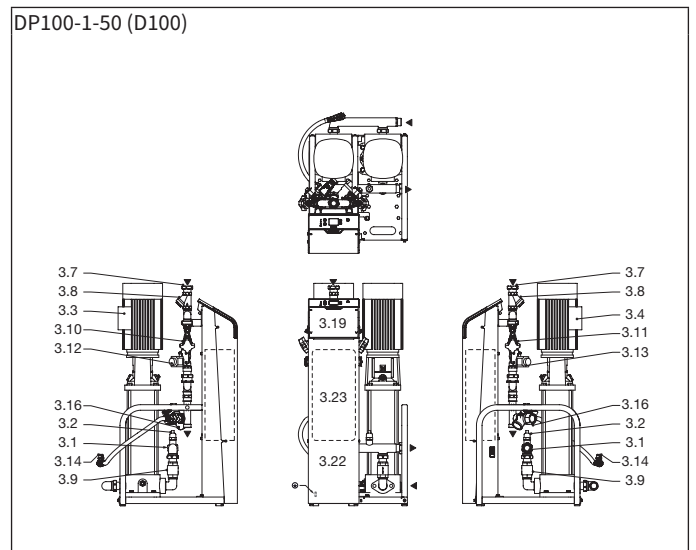
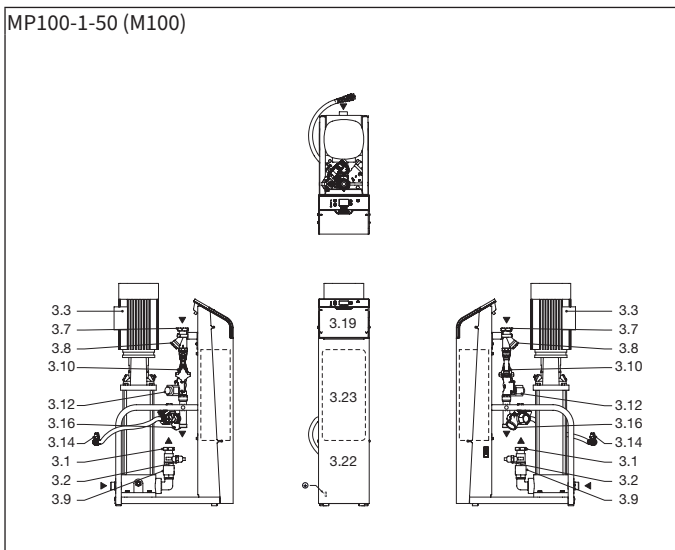
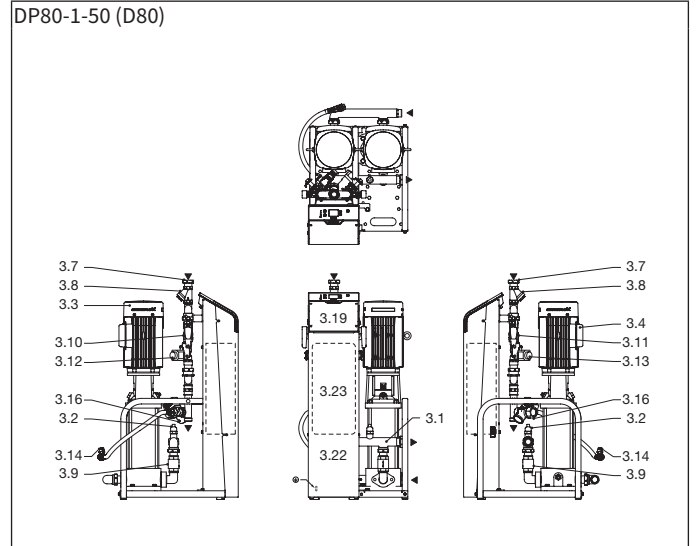
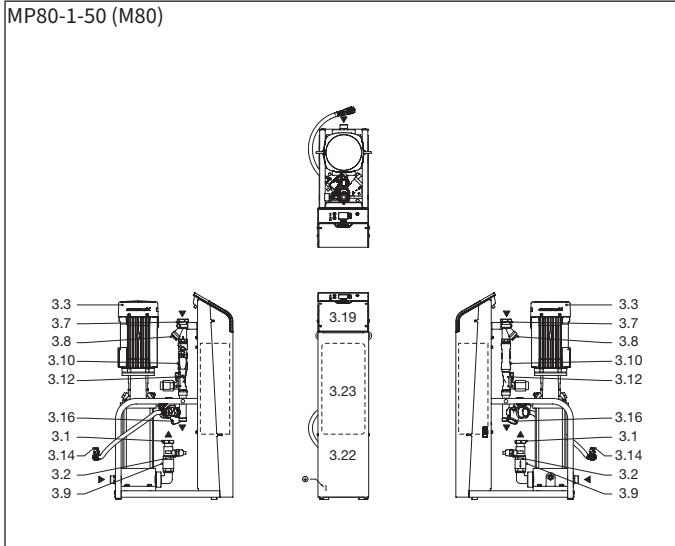

For item designations, [“5.6 Component parts, pump module” on page 19.](#)

## 5.7 Control unit

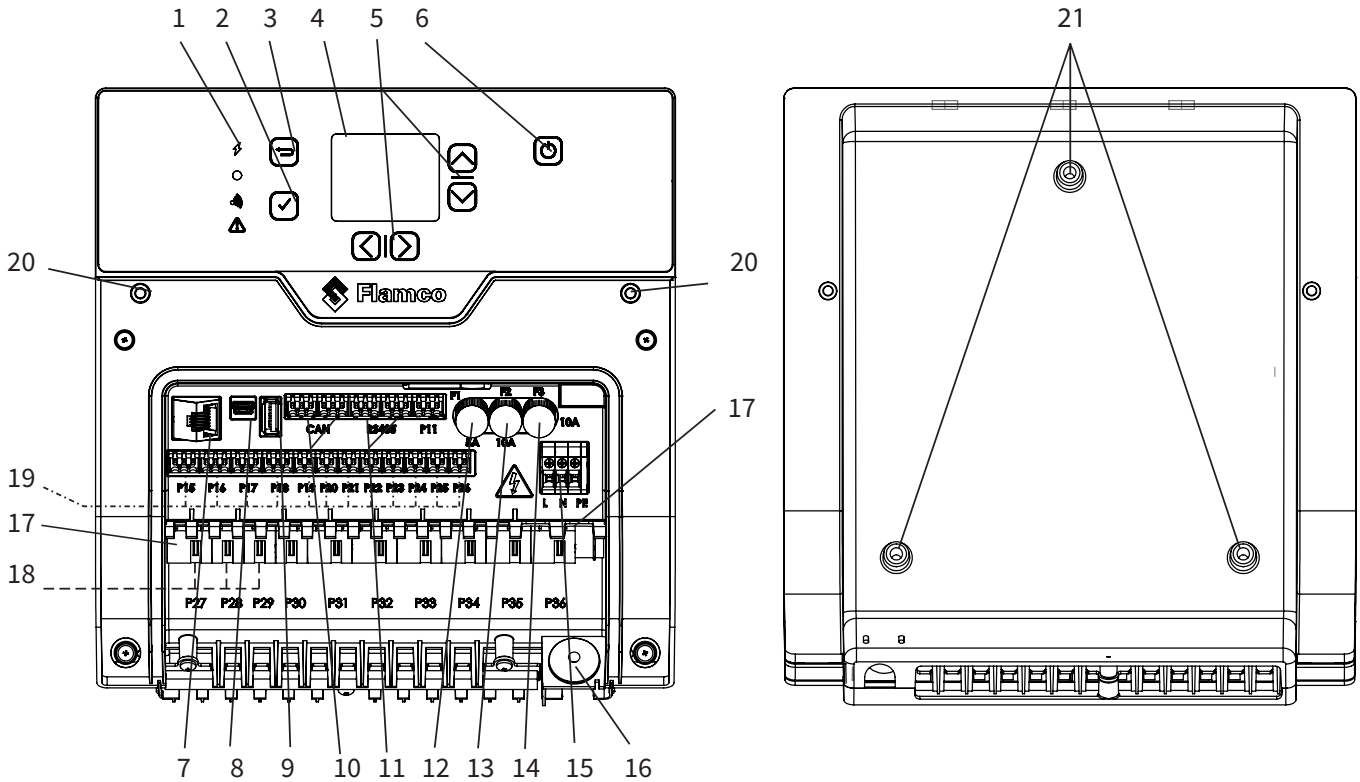

- |  |   |
|--|---|
| <p>1 LED indicator lights</p> <ul style="list-style-type: none"> <li>- LED, yellow on: Flextronic is powered.</li> <li>- LED, Green on: No errors, Automat is running correctly</li> <li>- LED, Blue on: Bluetooth is active</li> <li>- LED, Red on: Error occurred.</li> </ul> <p>2 Acceptance button</p> <p>3 Back button</p> <p>4 Full color display</p> <p>5 Navigation buttons</p> <p>6 ON/OFF button</p> <p>7 Ethernet port</p> <p>8 Micro-USB</p> | <p>9 USB</p> <p>10 CANbus port</p> <p>11 RS485 port</p> <p>12 F1, Fuse one (1) 5x20, 5A</p> <p>13 F2, Fuse two (2) 5x20, 10A</p> <p>14 F3, Fuse three (3) 5x20, 10A</p> <p>15 MAINS connection (L, N, PE)</p> <p>16 MAINS grommet</p> <p>17 Relay outputs</p> <p>18 Potential free outputs</p> <p>19 Sensor and switch inputs/outputs</p> <p>20 Mounting holes (Flamcomats, Vacumats)</p> <p>21 Mounting holes (ENA's, MKU/C's)</p> |
|--|---|

## 6. Assembly

### 6.1 Setup

A/B

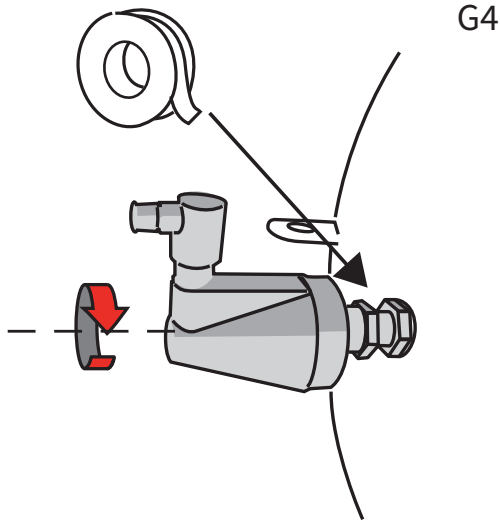

C (Flamcomat starter)

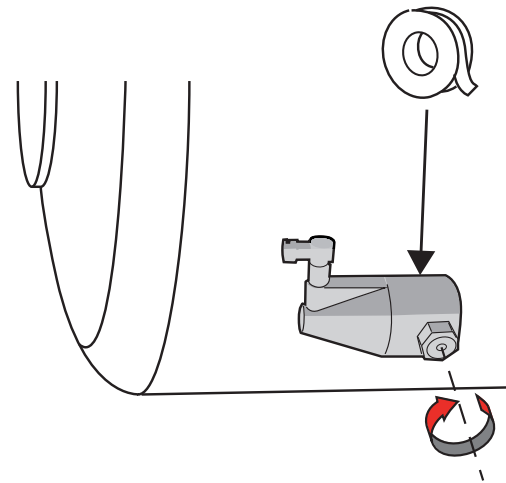

- Fit the automatic vent (supplied separately).
- Remove the transport seal by the volume sensor once the basic vessel has been set up in the proposed place and no further positional changes are necessary. Avoid impact on the sensor and make sure the sensor is on a surface which does not impair the function of the sensor pressure-pad.

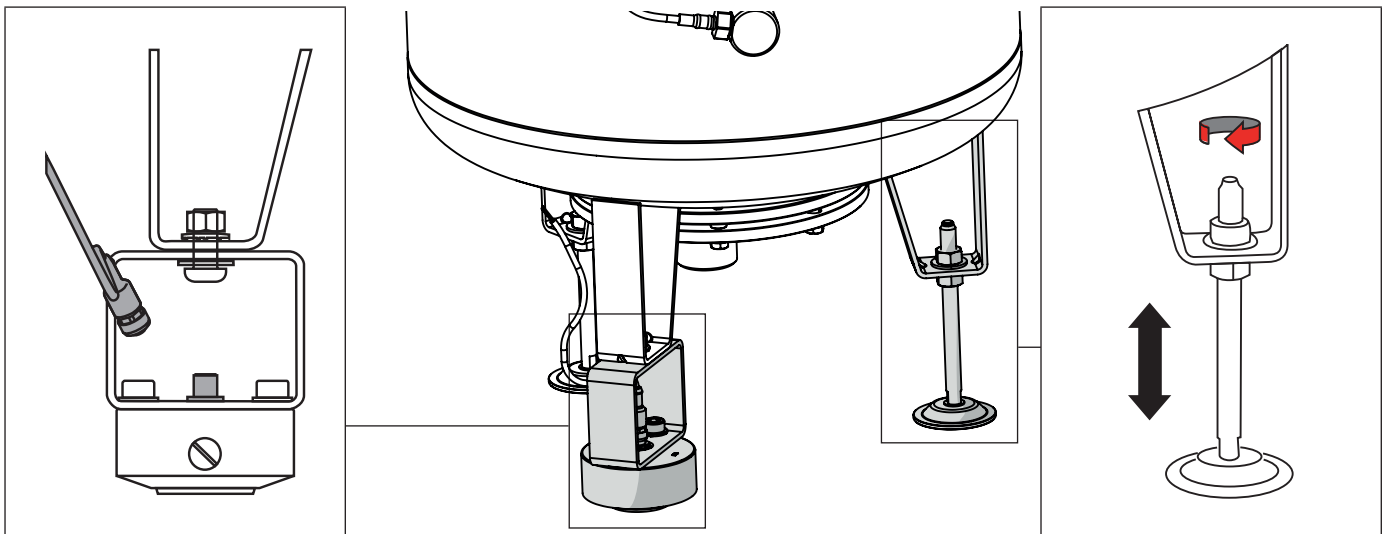

- Installation of the weight-capacity sensor and the adjustable feet.
- Using the foot-height adjuster, adjust the vessel until it is vertical. Use two vertical magnetic spirit levels.

- Ensure that no external additional forces can be exerted on the basic vessel (e.g. tools laid on the vessel, things leaning on the sides).
- Do not fix the basic vessel to the ground on which it is erected (do not use any sort of fastening which can adversely affect the vessel, e.g. sinking the feet into concrete or lime, welding of the vessel or its feet, clamps and ties on the body of the structure or appurtenances).
- Place the control module, the basic vessel and the auxiliary vessel at the same height.

## 6.2 Vessel connection

The vessel connection is produced as an electric or hydraulic connection to the pump module. For the installation diagram and example installation see [“Appendix 1.” on page 39](#). Please observe the following points prior to filling and commissioning of the pressure expansion vessels:

- Install the connection assembly between the vessel and the control module.



**Caution:** Ensure that the connection between the pump module and the basic vessel is made with the supplied flexible pressure hoses (connection assembly).

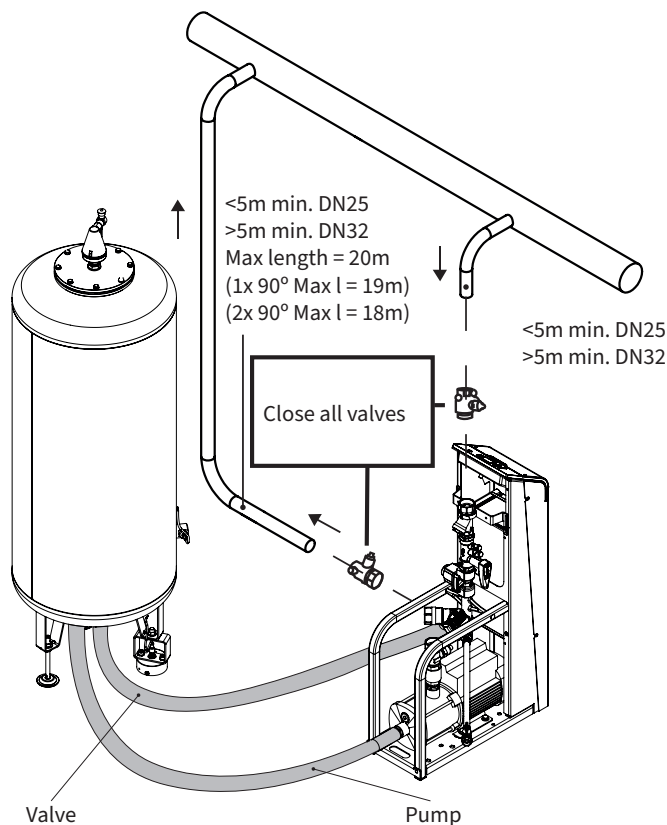

Take note of the labels ‘pump’ and ‘valve’ on the connections and connect up the appropriate connection from the pump module (valve) to the pump (valve) on the vessel connection.

Do not cross these connections and, if necessary, mount the vessel connection flange so as to enable parallel pipe fitting. Use the flat seals supplied.

- Connect the signal line via the quick-release connection to the capacity sensor. Screw this connection entirely into the connector (protection class IP67).
- Open the lockshield valve on the connection assembly between the vessel (basic vessel, intermediate vessel) and control module.

### 6.3 Top-up connection

The top-up connection should be connected to the control unit. Assured top-up requires an average set feed pressure of approx. 4-6 bar (max. 8 bar). High feed pressures may require devices to prevent water hammer (pressure reducing valve).

[“Appendix 1.” on page 39](#) shows the installation diagram and example installation.

Please observe the following specifications before filling and commissioning the pressure-expansion automat:

- Install the feed to the top-up hose with shut-off valve (as delivered).
- Avoid any tensile loads on the hose, bending radii of less than 50 mm and contractions.
- If the top-up feed is connected to the water main, a backflow preventer with filter must be connected in series in compliance with EN 806-4/EN 1717. Install this accessory horizontally and fit a shut-off valve before this assembly (note: clean filter regularly and change filters as and when required).



**Caution:** Connect the shut-off valve to the top-up intake.

### 6.4 Drain connection

To safely route the volume flows to be discharged at the safety valve (Pos. 3.16), backflow preventer (accessory, top-up) and the atmospheric pressure compensation connection (Pos.1.3) a drain is required in the vicinity of the Flamcomat equipment.

- Install a drain funnel and, if necessary, a drain pipe for the backflow preventer.
- When a discharge pipe is connected to the safety valve, the connection must be kept open to atmospheric pressure. An atmospheric funnel from the Flamco product catalogue can be fitted for this purpose.

## 6.5 System connection

The system connection should be connected to the heating or cooling system.

[“Appendix 1.” on page 39](#) shows the installation diagram and example installation.

Please observe the following specifications before filling and commissioning the pressure-expansion automat:

- The connection should preferably be made in the return line of the heating system. Please note that a temperature at the system connection  $> 70\text{ °C}$  (... $80\text{ °C}$ ) would exceed the permissible pump/diaphragm load and possibly lead to damage to components. (Complete insulation of the expansion pipe may increase the temperature load on the control unit and the diaphragm).
- Make sure that this connection is directly connected to the heat generator, and that there are no external hydraulic pressure influences present at the point of entrainment (e.g. hydraulic balancers, distributors).
- The flow determines how you should install the expansion lines. When fitting expansion lines to the return  $> 5\text{ m}$  in length, use pipes of at least one nominal diameter larger than that of the pump module. Avoid additional loads to the system connection of the control unit (e.g. from heat expansion, flow oscillations, dead weights).
- Equipment with flow temperatures  $> 100\text{ °C}$  must have a minimum pressure limiter fitted in the expansion line (system drain, valve drain pipework). The arrangement is contained in [“Appendix 1.” on page 39](#). In applications in accordance with DIN EN12828:2003 (D), this limiter is only envisaged for use if the pressure holding device does not have an automatic top-up system.
- Use sealants and pipework relevant to the installation; however, please observe at least the maximum permitted volumetric flow, pressure and temperature values for the expansion line in question (control unit/system inlet and outlet).
- Fit a non-return valve in the immediate vicinity of the system connection on the control unit that cannot be unintentionally shut off.



**Caution:** Close the lockshield valve at the system inlet and outlet of the control unit.

## 6.6 Electrical Installation

The provision of power supply, (protective) ground wire connection and line protection must be made in accordance with the regulations of the responsible power company and the applicable standards. The required information can be found on the type plate of the control unit, the terminal plan (labelling) and in [“Appendix 3.” on page 45.](#)

- All electrical connections should be carried out by a qualified and authorized electrician in accordance with the latest issue of the IET regulations. The equipment must be earthed. It is strongly recommended that a high-sensitivity differential switch (30mA) (residual current device RCD) is fitted on the incoming electrical supply.
- Do not remove covers without first ensuring that the electrical supply is suitably isolated and cannot be switched on.
- Do not attempt to supply electricity to the equipment unless the protective covers are correctly fitted and held securely in place.
- Cables connected to the controller volt free contacts may be supplied from another source and may remain live after the unit is isolated. These must be isolated elsewhere.
- The user or the installer is responsible for the installation of the correct earthing and protection according to valid national and local standards. All operations must be carried out by a qualified electrician.
- The Flamco equipment must be connected to a mains isolator switch with a contact gap of at least 3 mm
- It is recommended the switch should be installed within 2m of the equipment.



**Hint:** install equipotential bonding between earth connection and equipotential bonding conductor. The minimum diameter, quality and type of the power cables should apply to the on-site applicable rules and regulations for this application. The electrical control terminals must be connected at the set-up location to the mains power supply at the relevant operating voltage. The finished system allows the user to program the configuration and system-dependent parameters into the control unit.

Connect power cable (100 - 240 VAC ~1N PE, 50/60 Hz)

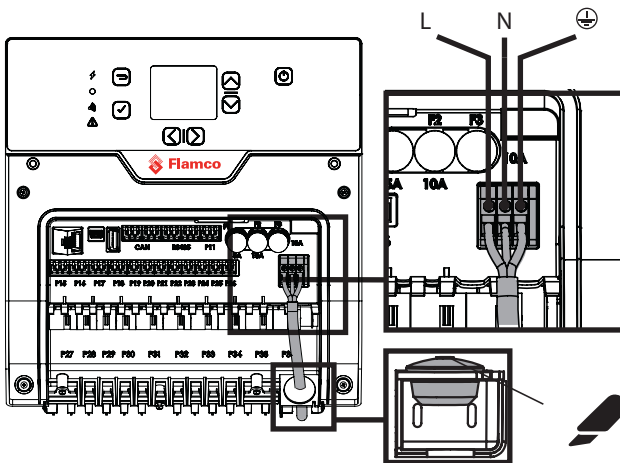

Connect power cable (400 VAC ~3N PE, 50/60 Hz)

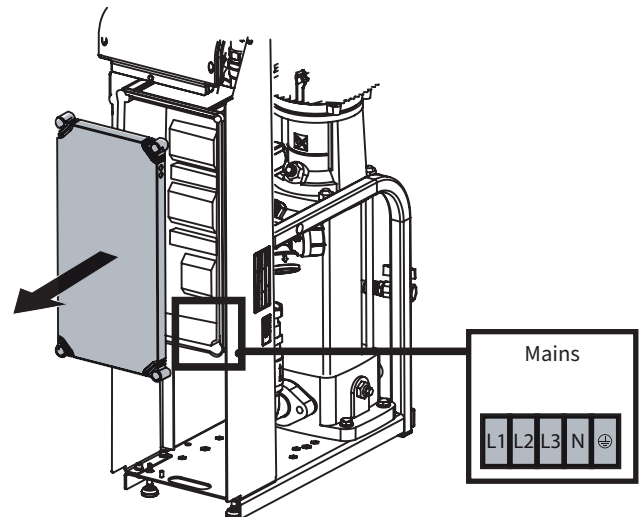

## 7. Commissioning

### 7.1 Initial commissioning

- Document the commissioning procedure (actions and settings).
- Check that the installation and other actions prior to use have been carried out in full (e.g. power supply available and connected, functioning or active fuses, seal tightness of the equipment, transport protection of the volume sensor removed).

**Commissioning is preferably done via Flamconnect App.**



**Caution:** Ensure that the basic vessel is not filled until all the commissioning measures have been completed.

- Adjust the manual control valve on the pump module (see [“Appendix 2.” on page 41](#)). On the M02, the second manual control valve must be set as well.
- Fill and de-aerate the heating or cooling system (not the vessel!)
- Check the operational readiness of the top-up line.
- Open the valve at the top-up connection and the lockshield valve at the flexible connection assembly (vessel connection).
- **SWITCH ON THE CONTROL UNIT** and run the Commissioning procedure ([“7.2 Overview menu options” on page 29](#), Commissioning).
- Selecting your language is part of the Commissioning procedure.
- Then the Flamcomat basic vessel marking shall be scanned with the Flamconnect App, or shall be selected based upon its nominal capacity ([“5.3 Markings” on page 17](#), name-plate Vessel) and consequently the factory-, operating calibration shall be performed. ([“7.2 Overview menu options” on page 29](#))
- This start-up procedure is followed by activating the top-up procedure. Once a volume level of approx. 7% has been reached (see display), **SWITCH OFF THE CONTROL UNIT AND DE-AERATE THE PUMP(S)** ([“5.5 Component parts, vessels and connection assembly” on page 18](#); pos. 3.5 B; 3.6 B, pos. 3.20). On pumps with automatic de-aeration, these must be opened by a single turn of the red cap on these components.
- Open the cap valve on the return circuit (system flow and return) Caution, the heating system pipes may be hot.
- Seal the lockshield valves.
- The completion of all the tasks to be carried out, the review of technical data, recommendations and explanations in this manual lead to the pressure expansion automat being ready for operation.
- **SWITCH ON THE CONTROL UNIT.**

Balancing valves on the pump unit may not be closed during operation as doing so may cause severe/destructive damage to the pump unit.

## 7.2 Overview menu options

Download Flamconnect app

### Commissioning

Icon	Name	Function
	Language selection	<i>To select the language of the interface</i>
	Time-Date setting	<i>To set the time and the date</i>
	Connect via App	<i>To pair your smartphone/tablet via wireless to proceed the commissioning with mobile</i>
	I have read the manual	<i>To confirm your awareness of the commissioning process</i>
	Vessel type selection- vessel calibration	<i>To select the (primary) vessel</i>
	Pressure setting	<i>To set the desired pressure setpoint</i>
	Accessoire selection	<i>To select the additional control function of the automat</i>
	Commissioning summary	<i>To confirm the automat settings</i>

### 7.3 Volume level and operating temperature

**Note:** If a different fill level is required than the self-established minimum level after start (operational ready and installed top-up), the vessel should be filled to reflect the minimum required level needed for the actual system temperature, after completing the commissioning procedure on the control unit. For better understanding, study the diagrams below and the paragraph on maintenance, vessel draining and re-filling later in this document.



**Note:** For Flamcomat Starter vessels ([“5.5 Component parts, vessels and connection assembly”](#) on page 18 reference C (Flamcomat Starter), handles a maximum filling level of 77%.

**Example 1**

Max. design temp.: 50 °C  
 Max. fill level: 92 %  
 Water feed, top-up: 12 %  
 Min. design temp.: 10 °C

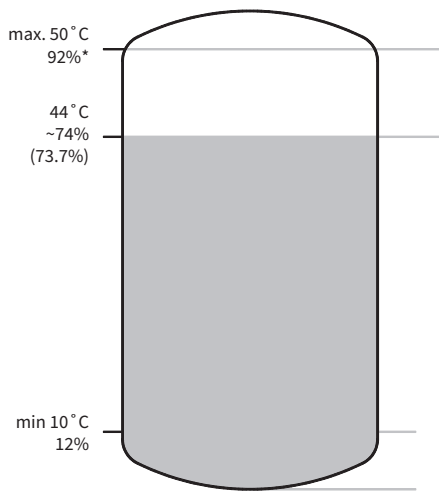

**Example 2**

Max. design temp.: 80 °C  
 Max. fill level: 92 %  
 Water feed, top-up: 12 %  
 Min. design temp.: 10 °C

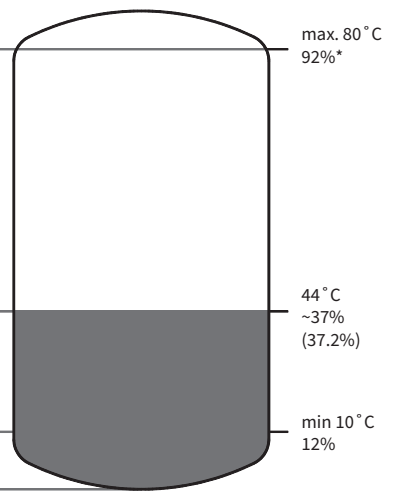
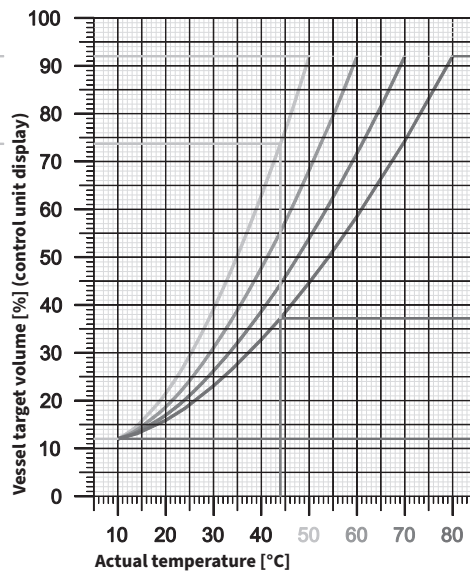

**Example 3**

Max. design temp.: 25 °C  
 Max. fill level: 92 %  
 Water feed, top-up: 12 %  
 Min. design temp.: 6 °C

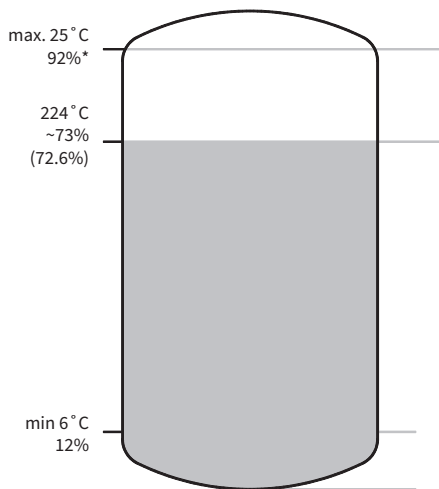

**Example 4**

Max. design temp.: 40 °C  
 Max. fill level: 92 %  
 Water feed, top-up: 12 %  
 Min. design temp.: 6 °C

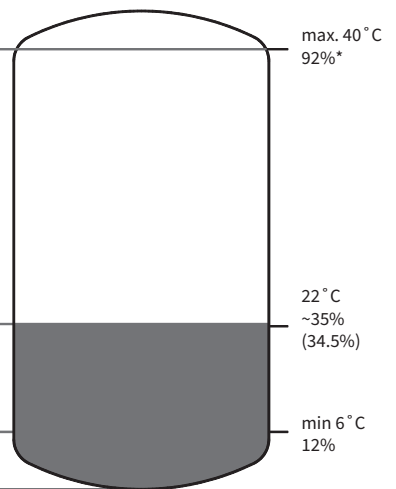
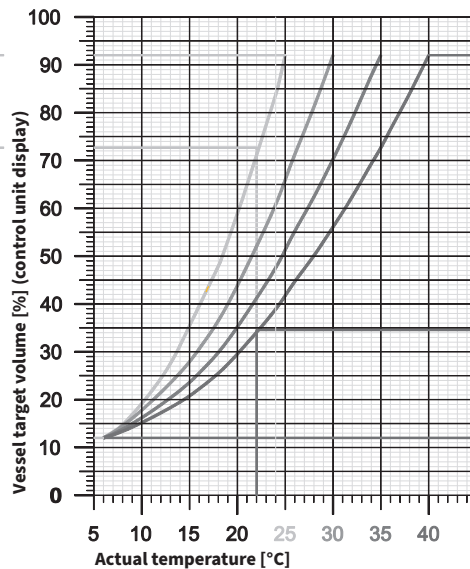



















Fig. FM.037.V01.15

## 7.4 Clarification of menu icons, function and location

Icon	Name	Function	Location
	Home	To observe the status of the automat	
	Settings	To launch the settings menu	
	Login	To login to access the advanced settings	
	Manual mode	To run a manual activation of the actuators	
	Service info	To observe the service information	
	Pressure	To change the operating pressure and the pressure tolerance interval	 
	Refill Level	To set the refill, drain and alarm levels	 
	Degassing	To select the degassing mode and the restricted hours profile	 
	General	To launch the general settings menu	 
	Alarms	To assign the alarm message(s) to the potential free output(s)	  
	Accessoires	To activate the advanced control accessories	  
	Time   Date	To set the time and the date	  
	Language	To change the language of the interface	  
	Factory reset*	To reset the automat	  
	Firmware update*	To update the firmware	  
	Date	To set the date	   

Icon	Name	Function	Location
	Time	To set the time	   
	System Info	To observe the automat and the controller information	 
	Error logbook	To read the last 30 error messages	 
	Maintenance	To see the next maintenance due date	 
	Operating Hours	To see the performace statistics	 
	USB detected	To save the log file to a USB stick	

\* Only available when logged in

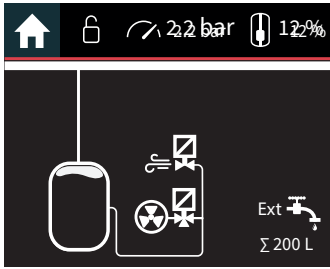

Operation screen

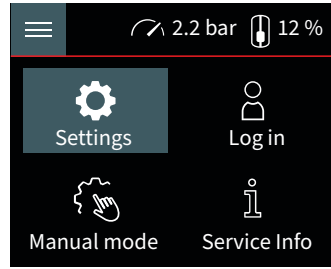

Menu screen

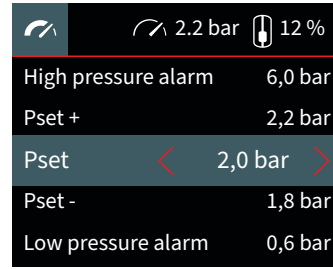

Settings screen

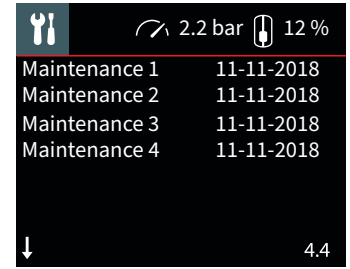

Read only screen

### Operation Screen

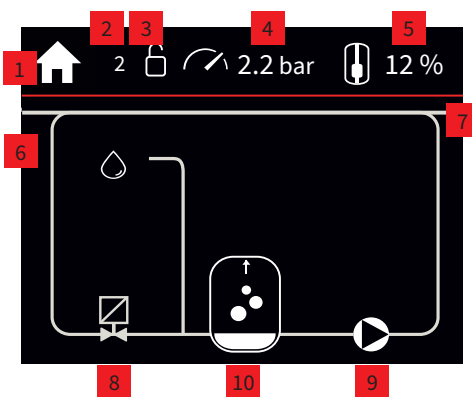

- 1 Screen icon
- 2 Node number
- 3 Logged in
- 4 Current System Pressure
- 5 Current vessel level
- 6 Refill
- 7 System
- 8 Valve(s)
- 9 Pump(s)
- 10 Vessel

- bubbles indicates degassing on/off
- animated bubbles indicate degassing active
- arrow indicates increase/decrease off water level in expansion vessel

### Pressure settings

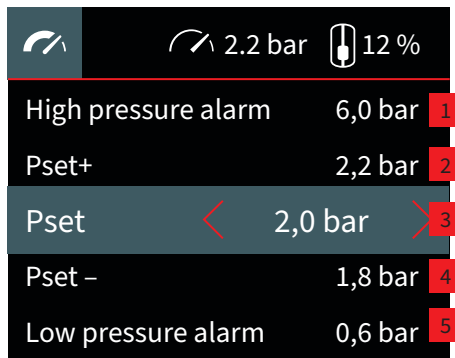

- 1 High pressure alarm
- 2 Upper operating pressure tolerance
- 3 Operating pressure
- 4 Lower operating pressure tolerance
- 5 Low pressure alarm

### Degassing settings

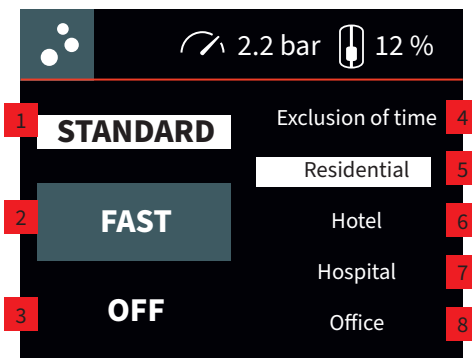



#### Main de-aeration function

- 1 Degassing mode normal
- 2 Degassing mode Turbo (24h of high frequency degassing)
- 3 Degassing mode OFF

#### Sleep interval settings of de-aeration function.

- 4 No silent hours profile active
- 5 Degassing possible on weekdays from 9.00 to 17.00
- 6 Degassing possible every day from 10.00 to 17.00
- 7 Degassing possible everyday from 9.00 to 21.00
- 8 Degassing possible on weekdays and Saturdays from 19.00 to 7.00 and Sunday

## 7.5 Top-up, operation with the water treatment module

	 2.2 bar	 12 %
Upper level limit		97 %
Drain Start		94 %
Drain Stop	< 92 % >	
Refill Stop		12 %
Refill Start		9 %

- Upper level limit
- Drain start
- Drain stop
- Refill stop
- Refill start
- Minimal level
- Low level limit
- Filter capacity
- Maximal Refill time per cycle
- Maximum Refill liters per cycle
- Refill interval
- Refill cycles per day

## 7.6 Malfunction messages

Procedures and values for error identification, evaluation and output have been tried in practice, prevent secondary failures and invite user awareness. Please note that incorrect set-up conditions can lead to repeated errors and inhibit the intended use. Examples of incorrect set-up conditions are: incorrect or no longer applicable design, outdated equipment, incorrect installation and inadmissible operational parameters.

Error #	GUI	Action
0	Single pump maximum run time error	Pump failure. Check functioning of pump. Call Technical support if no solution can be found.
1	Redundant pumps maximum run time error	Pump failure. Check functioning of pumps. Call Technical support if no solution can be found.
2	Load dependant pumps maximum run time error	Pump failure. Check functioning of pumps. Call Technical support if no solution can be found.
3	Single pump current error	Potential failure of pump. Check electrical connection of pump. Call Technical support if no solution can be found.
4	Pump A current error (double pump configuration)	Potential failure of pump. Check electrical connection of pumps. Call Technical support if no solution can be found.
5	Pump B current error (double pump configuration)	Potential failure of pump. Check electrical connection of pumps. Call Technical support if no solution can be found.
6	Pumps A and B current error (double pump c configuration)	Potential failure of pump. Check electrical connection of pumps. Call Technical support if no solution can be found.
7	Pump C current error	Potential failure of pump. Check electrical connection of pumps. Call Technical support if no solution can be found.
8	Self-learning valve correction error	Please reset the error by acknowledging the error in current error/warnings
9	Self-learning pump correction error	Please reset the error by acknowledging the error in current error/warnings
10	Pressure sensor current exceeded	Check if the cable to the pressure sensor is not damaged
11	Pressure sensor no current	Check if the cable to the pressure sensor is connected
12	Load cell current exceeded	Check if the cable to the level sensor is not damaged
13	Load cell no current	Check if the cable to the level sensor is connected
14	Pump A power consumption too high	Potential failure of pump. Check electrical connection of pump. Call Technical support if no solution can be found.
15	Pump B power consumption too high	Potential failure of pump. Check electrical connection of pump. Call Technical support if no solution can be found.
16	Pump C power consumption too high	Potential failure of pump. Check electrical connection of pump. Call Technical support if no solution can be found.

Error #	GUI	Action
17	Maximum run time M1 exceeded	The pump runs too long. Please make sure there is no leakage in the system
18	Maximum run time M2 exceeded	The pump runs too long. Please make sure there is no leakage in the system
19	Maximum supplantation threaded water amount exceeded	Please replace a filter
20	Pump running, no decrease of water level in vessel	Potential failure of pump(s) or clogged vessel drain tube
21	Valve open, no increase of water level in vessel	Potential failure of valve(s) or clogged vessel supply tube
22	Maximum run time V1 exceeded	The valve runs too long. Please make sure that the balancing valve settings is correct
23	Maximum run time V2 exceeded	The valve runs too long. Please make sure that the balancing valve settings is correct
24	To run quick fill	Acknowledge error in current errors/warnings to run Quick fill
25	To run system fill	Acknowledge error in current errors/warnings to run System fill
26	System run in auto mode	You have left the manual mode. Automat maintains the pressure
27	Quick system filling active, V to stop	Press V to stop/pause Quick System fill
28	System filling active, V to stop	Press V to stop/pause System fill
29	Manual mode active, press V to start automat	Acknowledge this message to run the automat in the AUTO mode (to leave the MANUAL mode)
30	Diaphragm rupture	The membrane is ruptured and should be replaced
32	Water level increase in vessel without Flamcomat activity	Potential failure of manifold-, refill- or check valve
33	Water level decrease in vessel without Flamcomat activity	Potential leakage of vessel or connection sets, or failure of drain valve
34	Maintenance is due 1	Carry out maintainance 1 (equipment service, every 1 year)
35	Initial fill failed	Potential failure of refill valve or clogged supply tube
36	Maximum refill time exceeded	Potential failure of refill valve
37	Maximum drain time exceeded	Potential failure of drain valve
38	No refill flow	Please make sure the liter counter is available
39	Amount refill water too much	System requires to much refill. Potential leakage
43	Initial fill active	The automat fills a vessel with minimum amount of water
44	Manual initial fill active	Fill in a vessel with minimum amount of water
45	System fill timer expired	System fill took too long. Please check the system and restart the filling process
46	Quick fill timer expired	System fill took too long. Please check the system and restart the filling process
47	Maintenance is due 2	Carry out maintenance 2 (inspect vessel internally, every 5 years)
48	Maintenance is due 3	Carry out maintenance 3 (strength inspection to vessel, every 10 years)
49	Maintenance is due 4	Carry out maintenance 4 (inspect electrical equipment, every 1,5 years)
64	Low pressure alarm	System pressure is lower than "Low Pressure Alarm"
65	Higher pressure exceeded	System pressure is higher than "High Pressure Alarm"
66	Water Level below minimum value	Water level in a vessel is lower than "Low level limit"
67	Water Level above maximum value	Water level in a vessel is higher than "High level limit"
68	Pressure below minimum value	The risk of a steam formation. Turn off a boiler
69	Dry run protection	The refill pump cannot start as it is dry
70	Critical Water Level	Water level in a vessel is lower than "Minimal level limit"
72	Temperature too high	The temperature on the automat inlet is higher than 70°C. Please use an intermediate vessel
73	Time between refill processes too short	System requires to much refill. Potential leakage
74	Number of refills within certain time exceeded	System requires to much refill. Potential leakage
75	Don't lean on vessel	

## 7.7 Restarting

### After long periods of downtime:

- If this downtime was planned or scheduled, turn OFF the control unit and close off the lockshield valves to the system and the isolating valve to the top-up line. After that decompress and then drain the water area. We recommend you carry out maintenance before restarting (see Maintenance section).
- Use the commissioning records for restarting and check especially for system changes that can lead to other operating conditions of the expansion automat (e.g. system pressure).

### If the power supply has failed:

- The target parameters and default settings for pressure, aeration and top-up will remain unchanged, meaning automatic operation will resume automatically when power is restored (control unit ON). Extraordinary system operating conditions (e.g. cooling to below the default setting) may fall outside the permitted settings of the expansion vessel.



**Caution:** please ensure that when the system cools down or warms up, the minimum or maximum system pressure does not exceed or fall below the permitted operating pressure. Under- and over-pressure safety for operation of heating or cooling systems are not within the standard scope of supply of the Flamcomat.

Check the automat's operation once power supply has been restored and, if necessary, set the actual date and time values (overview menu options).

## 8. Maintenance

Electrical supply must be disconnected prior to conducting any maintenance. To supplement, or in addition to, the stipulations made in the overall project, perform the following:

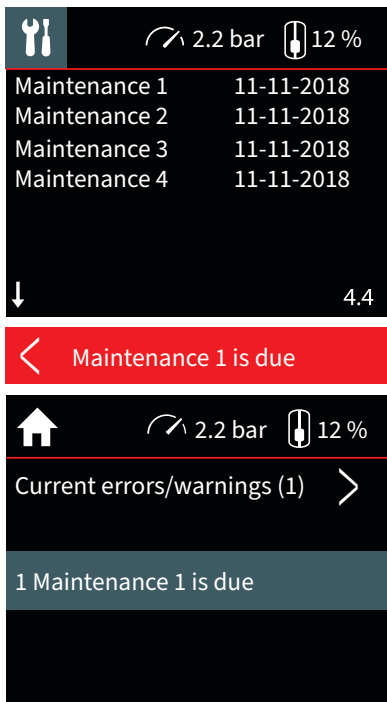

Maintenance due date is shown in menu 4.4.

Maintenance error pops-up when date is due. Error gets stored in the Current errors/warnings list and Error logbook.

Aknowledging the “maintenance 1 is due” error in the Current errors/warnings list is equal to resetting the maintenance 1 due date.

		Objects, standard scope of supply	Service activities, measures
Maintenance 1	365 Days	Particle filter 3.8 * Particle filter back-flow security (only when installed)	Clean filter insert and housing
		Air-intake preventer, bleeder valve 1.2 *, automatic breather 3.18*	Clean and check function. Unscrew the cap and take out the inner spring and ball-bearing for cleaning. Re-assemble in reverse order. Screw the cap back on and open it with a single turn.
		Primer valve 3.10; 3.11 *	Check and reset the pre-sets as in diagrams (see <a href="#">“Appendix 2.” on page 41</a> ; seal the valve)
		Pump 3.3, 3.6 *, valve 1, 2, 3.12, 3.13 *, valve 3 *, water meter 3.14 *	Function check. To be carried out manually by trained and certified personnel. Other inspections can be done during operation of the Flamcomat equipment (observe). Bleed pumps (except for MP/DP 60)
		Control unit 3.19*, configuration	Inspect and restore the required settings (overview menu)
		Vessel 1 *, pump module 3 *	Inspect and repair the leak-tightness of all hydraulic connections to the water areas. Check the screw connections for tightness, check the exterior for damage, deformation or corrosion and restore to operational readiness.
		Safety valve 3.16 *	Function check. To be carried out manually by trained and certified personnel. This requires the lockshield valve 2.1* on the connection assembly.
Maintenance 2	1825 Days		Inspect vessel internally! Consider recurring inspections, see general safety instructions!
Maintenance 3	3650 Days		Carry out strength inspection to vessel!
Maintenance 4	584 Days		Carry out recurring inspection of electrical equipment!

\* See [“5.6 Component parts, pump module” on page 19.](#)

## 8.1 Vessel draining/refilling.

If draining of expansion water in the main vessel or auxiliary vessels is necessary, please consider the following order of actions:

- Record the actual volume level (%) as shown on FLEXTRONIC control unit display.
- Switch the control unit OFF (hold O/I button for 8 seconds).
- Close the lockshield valves on the expansion pipe (system inlet and outlet) and on the connecting array (vessel inlet and outlet)
- Close the isolating valve at the top-up connection.
- Carry out the required work on the vessel (drain, service, repair etc.).
- Switch the control unit ON; Login and go to factory reset\* and run Commissioning procedure (overview menu options; Commissioning 1-1.8)
- After commissioning the Initial filling procedure is started automatically.
- Note: when a refill bigger than the default setting for minimum vessel filling volume is required (6%), please switch off the degassing function (Degassing settings menu). The filling should preferably take place over the vessel connection valve (marking). If both the main and auxiliary vessels need filling, open the lockshield valve on each vessel connection (flow and return). Make sure that the volume level detection is made by using the volume sensor of the main vessel.
- Disconnect the filling equipment.
- Open all previously closed valves (seal) and bleed the pump(s).
- Optionally the de-aeration function can be switched ON again.
- The operational mode has been restored.

\* There are 2 questions in this menu item. Only when these are confirmed, the reset takes place.



**Caution:** At the moment of restarting the system some logical errors may arise that are self-acknowledging or acknowledged.

## 9. Decommissioning, dismantling

At the end of the service life or at planned shut-down of the equipment, please make sure that the module is separated from the power supply. The hydraulic system connections and top-up connections should be closed off.



**Caution:** water areas should first be made pressureless and empty when the destination or re-use of system water should be designated in conformity with the applicable rules. This water may be treated, contain anti-freeze or other additives.

The designation of further processing of the construction parts should be carried out in agreement with the required waste management service provider.

# Appendix 1.

## Technical data, information



Caution: **DO NOT STACK!**

### Ambient conditions

Storage		
Room:	Protected against:	Ambient conditions:
Locked	Solar radiation	60 ... 70 % relative humidity, non-condensing
Frost-free	Thermal radiation	Maximum temperature 50 °C
Dry	Vibration	Free of electrically conductive gases, explosive gas mixtures, aggressive atmosphere

Operations room		
Room:	Protected against:	Ambient conditions:
Locked	Solar radiation	60 ... 70 % relative humidity, non-condensing; temperature 3 - 40 °C
frost-free,	thermal radiation	depending on type 3 - 50 °C;
dry	vibration.	free of electrically conductive gases, explosive gas mixtures, aggressive atmosphere. Caution: Higher temperatures may lead to overload of the drive system.

### Minimum distances

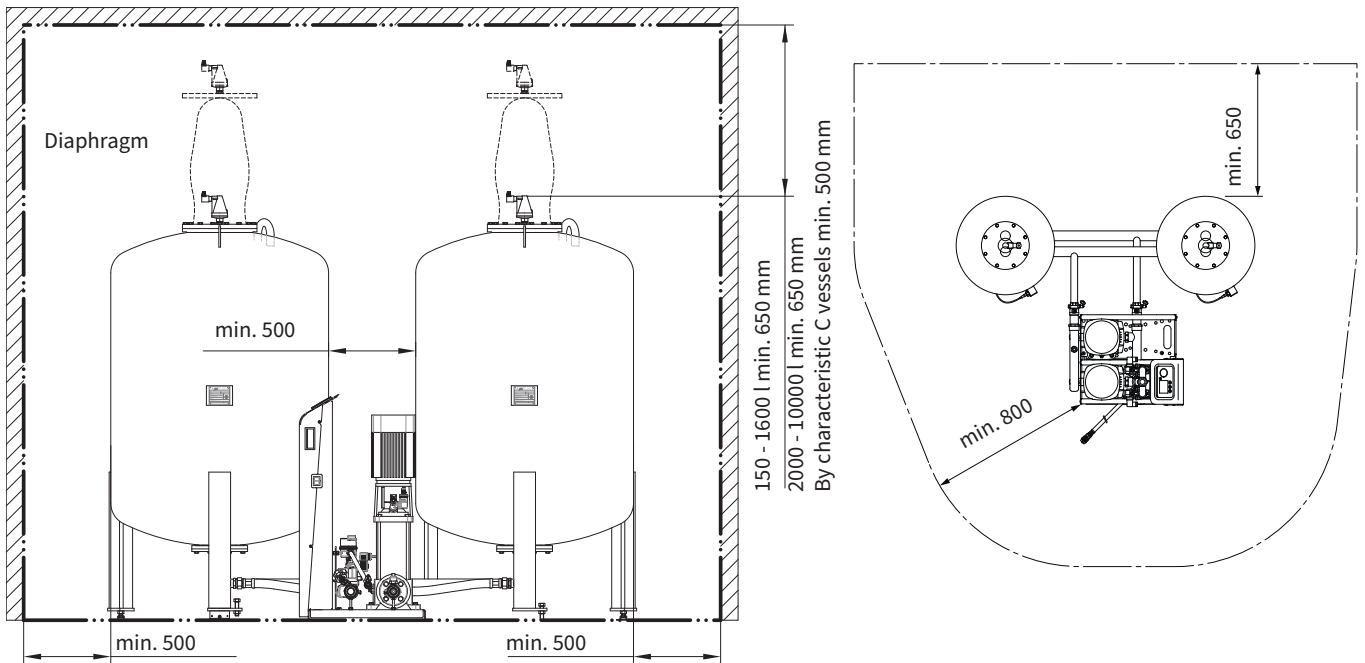

## Installation examples

Distance system supply, system discharge, at return integration point, in the range 0.5 ... 1 ... m.



**Please note:** If the return line is routed horizontally, do not implement the connection from below to avoid additional contamination with dirt.

- 1) For design temperatures  $> 100\text{ }^{\circ}\text{C}$  and  $> 110\text{ }^{\circ}\text{C}$ , additional requirements from applicable European standards may apply.
- 2) Not required acc. to DIN EN 12828
- 3) Add additional auxiliary vessels symmetrically using a collector line (main vessel at centre) taking into account minimum distances.  
The branch from the main vessel must be flexible.

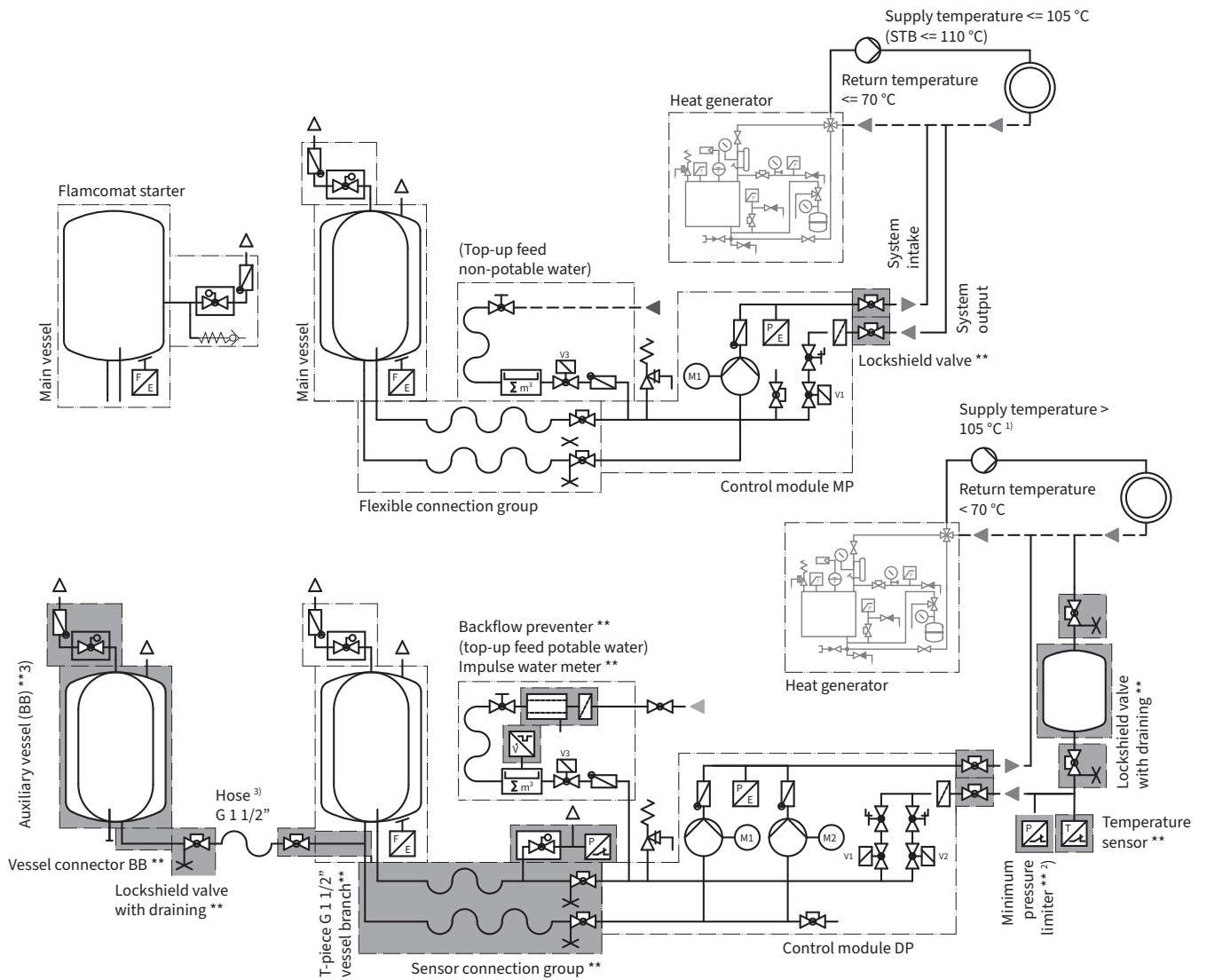

\*\* accessory, optional extra

## Appendix 2.

### Technical data, specifications, hydraulic equipment

#### Vessels: volume, dimensions and weights

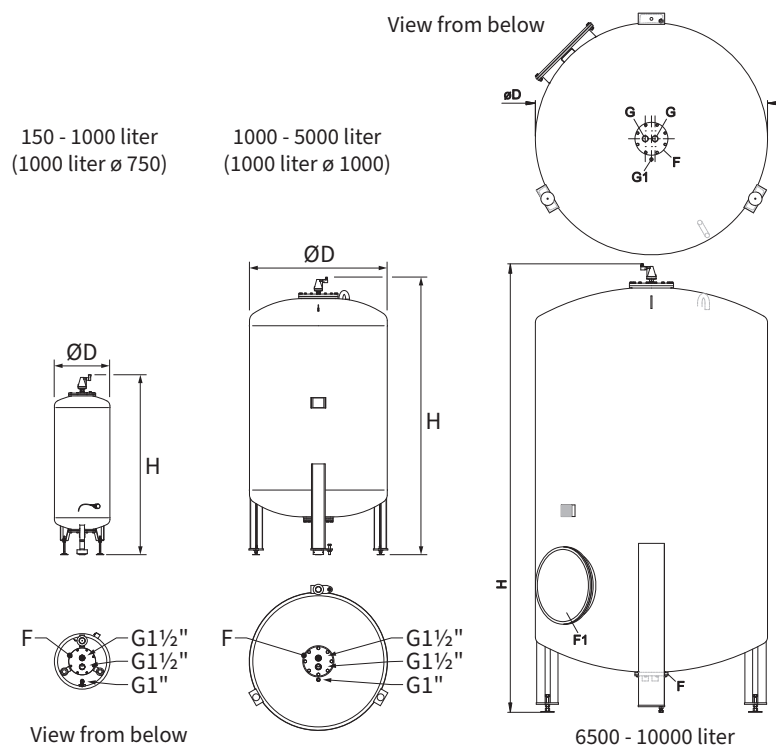

Nominal capacity [litres]	Vessel diameter D (Characteristic C) [mm]	Maximum height H (Characteristic C) [mm]	Vessel connector feed return G [G; inch]	Condensate drain G1 [G; inch]	Vessel flange F [DN]	Vessel flange F1 [DN]	Deadweight (as delivered, without packaging) (Characteristic C) [kg]
100	484 (484)	1050 (904)	1½"	½"	165		35 (27)
200	484 (600)	1560 (1081)	1½"	½"	165		31 (42)
300	600 (600)	1596 (1451)	1½"	½"	165		41 (56)
400	790 (790)	1437 (1293)	1½"	½"	165		62 (76)
500	790	1587	1½"	½"	165		70
600	790 (790)	1737 (1653)	1½"	½"	165		77 (97)
800	790	2144	1½"	½"	165		92
1000	790	2493	1½"	½"	165		106
1200	1000	2210	1½"	½"	165		291
1600	1000	2710	1½"	½"	165		346
2000	1200	2440	1½"	½"	165		431
2800	1200	3040	1½"	½"	165		516
3500	1200	3840	1½"	½"	165		626
5000	1500	3570	1½"	½"	165		1241
6500	1800	3500	1½"	½"	165	500	1711
8000	1900	3650	1½"	½"	165	500	1831
10000	2000	4050	1½"	½"	165	500	2026





## Vessel: operational characteristics

Nominal capacity [litres]	Permissible positive operating pressure [bar]	Positive test pressure [bar]	Temperature min. (design) [°C]	Temperature max. (design) [°C]	Permissible permanent temperature at the diaphragm min. [°C]	Permissible permanent temperature at the diaphragm max. [°C]
100 - 10000	3	4,72	0	120	0	70

## Pump module: dimensions and weights

Type		Height [mm]	Length [mm]	Width [mm]	Connection array (vessel) [G, inch]	Connection system [G, inch]	Connection top-up [Rp, inch]	Dead weight (as delivered condition without packaging) [kg]
	MP M-2-50 (MM G4)	930	530	230	1" M	1 1/4" F	1/2"	22
	MP 2-3-50 (M02 G4)	930	530	230	1" M	1 1/4" F	1/2"	28
	MP 10-1-50 (M10 G4)	930	530	230	1" M	1 1/4" F	1/2"	35
	MP 20-2-50 (M20 G4)	930	570	230	1" M	1 1/4" F	1/2"	35
	MP 60-1-50 (M60 G4)	930	550	230	1" M	1 1/4" F	1/2"	53
	MP 80-1-50 (M80 G4)	930	550	230	1" M	1 1/4" F	1/2"	68
	MP 100-1-50 (M100 G4)	1000	550	230	1" M	1 1/4" F	1/2"	67
	MP 130-1-50 (M130 G4)	1190	610	230	1" M	1 1/4" F	1/2"	75
	DP M-2-50 (DM G4)	970	530	230	1" M	1 1/4" F	1/2"	29
	DP 2-3-50 (D02 G4)	970	600	480	1" M	1 1/4" F	1/2"	45
	DP 10-1-50 (D10 G4)	970	600	480	1" M	1 1/4" F	1/2"	61
	DP 20-2-50 (D20 G4)	970	600	480	1" M	1 1/4" F	1/2"	61
	DP 60-1-50 (D60 G4)	970	600	480	1" M	1 1/4" F	1/2"	61
	DP 80-1-50 (D80 G4)	980	600	480	1" M	1 1/4" F	1/2"	115
	DP 100-1-50 (D100 G4)	1000	600	480	1" M	1 1/4" F	1/2"	134
	DP 130-1-50 (D130 G4)	1190	600	480	1" M	1 1/4" F	1/2"	153

## Control module external pressure retention, operational characteristics

	Type		Permissible positive operating pressure [bar]	Permissible media temperature min. / max. [°C]	Permissible environmental temperature min. / max.[°C]
	MP M-2-50	(MM G4)	6	3 / 70	3 / 40
	MP 2-3-50	(M02 G4)	10	3 / 70	3 / 40
	MP 10-1-50	(M10 G4)	10	3 / 70	3 / 50
	MP 20-2-50	(M20 G4)	10	3 / 70	3 / 40
	MP 60-1-50	(M60 G4)	10	3 / 70	3 / 50
	MP 80-1-50	(M80 G4)	16	3 / 70	3 / 50
	MP 100-1-50	(M100 G4)	16	3 / 70	3 / 50
	MP 130-1-50	(M130 G4)	16	3 / 70	3 / 50
	DP M-2-50	(DM G4)	6	3 / 70	3 / 40
	DP 2-3-50	(D02 G4)	10	3 / 70	3 / 40
	DP 10-1-50	(D10 G4)	10	3 / 70	3 / 50
	DP 20-2-50	(D20 G4)	10	3 / 70	3 / 40
	DP 60-1-50	(D60 G4)	10	3 / 70	3 / 50
	DP 80-1-50	(D80 G4)	16	3 / 70	3 / 50
	DP 100-1-50	(D100 G4)	16	3 / 70	3 / 50
	DP 130-1-50	(D130 G4)	16	3 / 70	3 / 50

## Control module external pressure retention, manual control valve, adjustment values

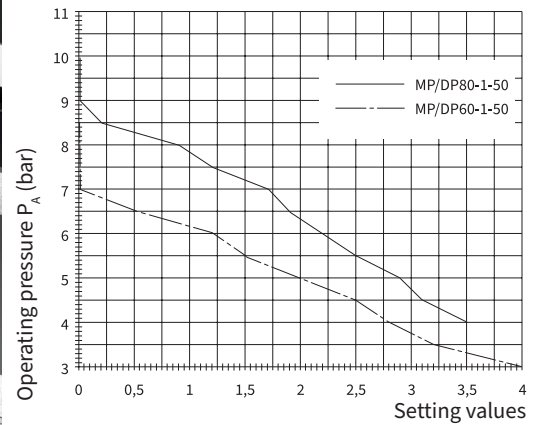
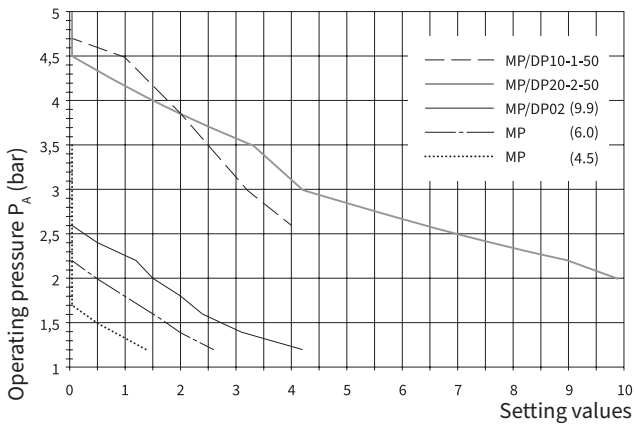

Setting values manual regulated valve M02 after pump see paragraph "Component parts", equipment [3,23].

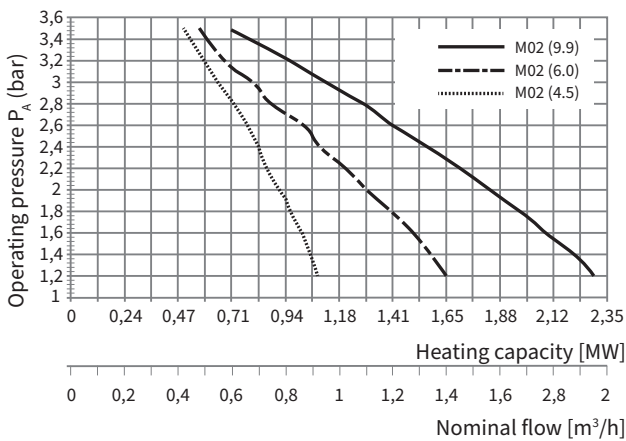

Manual control valve  
(Pos. 3.10; 3.11; page 19...21)

**Version MP**

(M M ÷ M130) - Valve 1,

**Version DP**

(D M ÷ D130) - Valve 1 and 2

**Example**

MP / DP 02-2-50 (M02/D02):

Operating pressure 3.8 bar

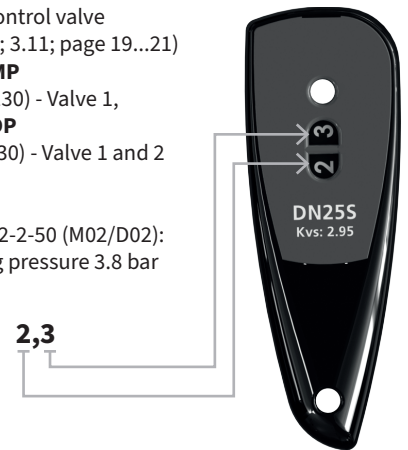

## Control module external pressure retention, top-up, flow rate

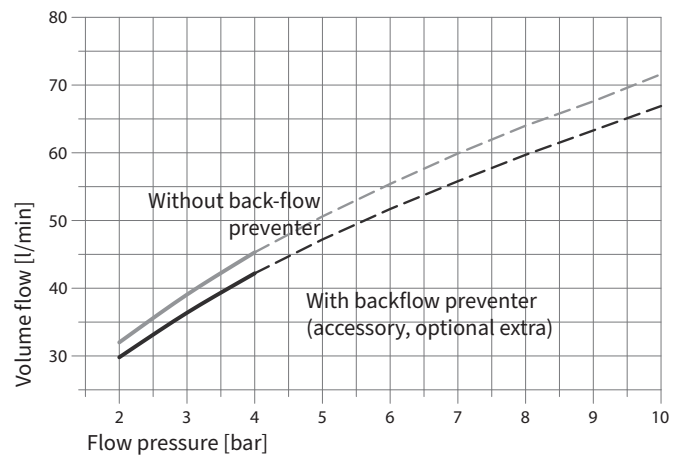
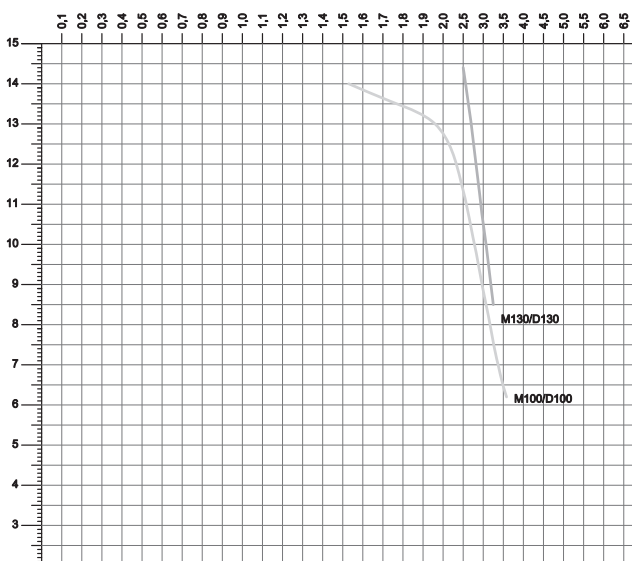

## Appendix 3.

### Technical data, information, electrical equipment

#### Pump unit, nominal values

Type	Nominal voltage	Rated current [A]*	Rated power [kW]	External fuses T (K) [A]	Protection class of pump unit
MP M-2-50 (MM G4)	230 V ~1 N PE 50 Hz	0,43	0,09	16	IP44
MP 2-3-50 (M02 G4)	230 V ~1 N PE 50 Hz	2,77	0,62	16	IP44
MP 10-1-50 (M10 G4)	230 V ~1 N PE 50 Hz	4,4	0,75	16	IP44
MP 20-2-50 (M20 G4)	230 V ~1 N PE 50 Hz	7,2	1,1	16	IP44
MP 60-1-50 (M60 G4)	230 V ~1 N PE 50 Hz	7,4	1,1	16	IP44
MP 80-1-50 (M80 G4)	400 V ~3 N PE 50 Hz	3,4	1,5	16	IP44
MP 100-1-50 (M100 G4)	400 V ~3 N PE 50 Hz	4,75	2,2	16	IP44
MP 130-1-50 (M130 G4)	400 V ~3 N PE 50 Hz	6,4	3,0	16	IP44
DP M-2-50 (DM G4)	230 V ~1 N PE 50 Hz	0,86	0,18	16	IP44
DP 2-3-50 (D02 G4)	230 V ~1 N PE 50 Hz	5,54	1,24	16	IP44
DP 10-1-50 (D10 G4)	230 V ~1 N PE 50 Hz	8,8	1,5	16	IP44
DP 20-2-50 (D20 G4)	230 V ~1 N PE 50 Hz	14,4	2,2	16	IP44
DP 60-1-50 (D60 G4)	230 V ~1 N PE 50 Hz	14,8	2,2	16	IP44
DP 80-1-50 (D80 G4)	400 V ~3 N PE 50 Hz	6,8	3,0	16	IP44
DP 100-1-50 (D100 G4)	400 V ~3 N PE 50 Hz	9,5	4,4	16	IP44
DP 130-1-50 (D130 G4)	400 V ~3 N PE 50 Hz	12,8	6,0	16	IP44
MP 2-1-60 M02 G4	230 V ~1 N PE 60 Hz	4,10	0,60	16	IP44
MP 10-1-60 M10 G4	230 V ~1 N PE 60 Hz	5,80	0,67	16	IP44
MP 20-2-60 M20 G4	230 V ~1 N PE 60 Hz	7,98	1,33	16	IP44
MP 60-1-60 M60 G4	400 V ~3 N PE 60 Hz	3,10	1,50	16	IP44
MP 80-1-60 M80 G4	400 V ~3 N PE 60 Hz	3,10	1,50	16	IP44
MP 100-1-60 M100 G4	400 V ~3 N PE 60 Hz	4,50	2,20	16	IP44
MP 130-1-60 M130 G4	400 V ~3 N PE 60 Hz	6,20	3,00	16	IP44
DP 2-1-60 D02 G4	230 V ~1 N PE 60 Hz	8,20	1,20	16	IP44
DP 10-1-60 D10 G4	230 V ~1 N PE 60 Hz	11,60	1,36	16	IP44
DP 20-2-60 D20 G4	400 V ~3 N PE 60 Hz	5,96	2,66	16	IP44
DP 60-1-60 D60 G4	400 V ~3 N PE 60 Hz	6,20	3,00	16	IP44
DP 80-1-60 D80 G4	400 V ~3 N PE 60 Hz	6,20	3,00	16	IP44
DP 100-1-60 D100 G4	400 V ~3 N PE 60 Hz	9,00	4,40	16	IP44
DP 130-1-60 D130 G4	400 V ~3 N PE 60 Hz	12,40	6,00	16	IP44

\* The rated current of the refill unit Flexfill-P - 1.2A (0.3kW)

# Control unit, terminal plans

## Flextronic terminal plan

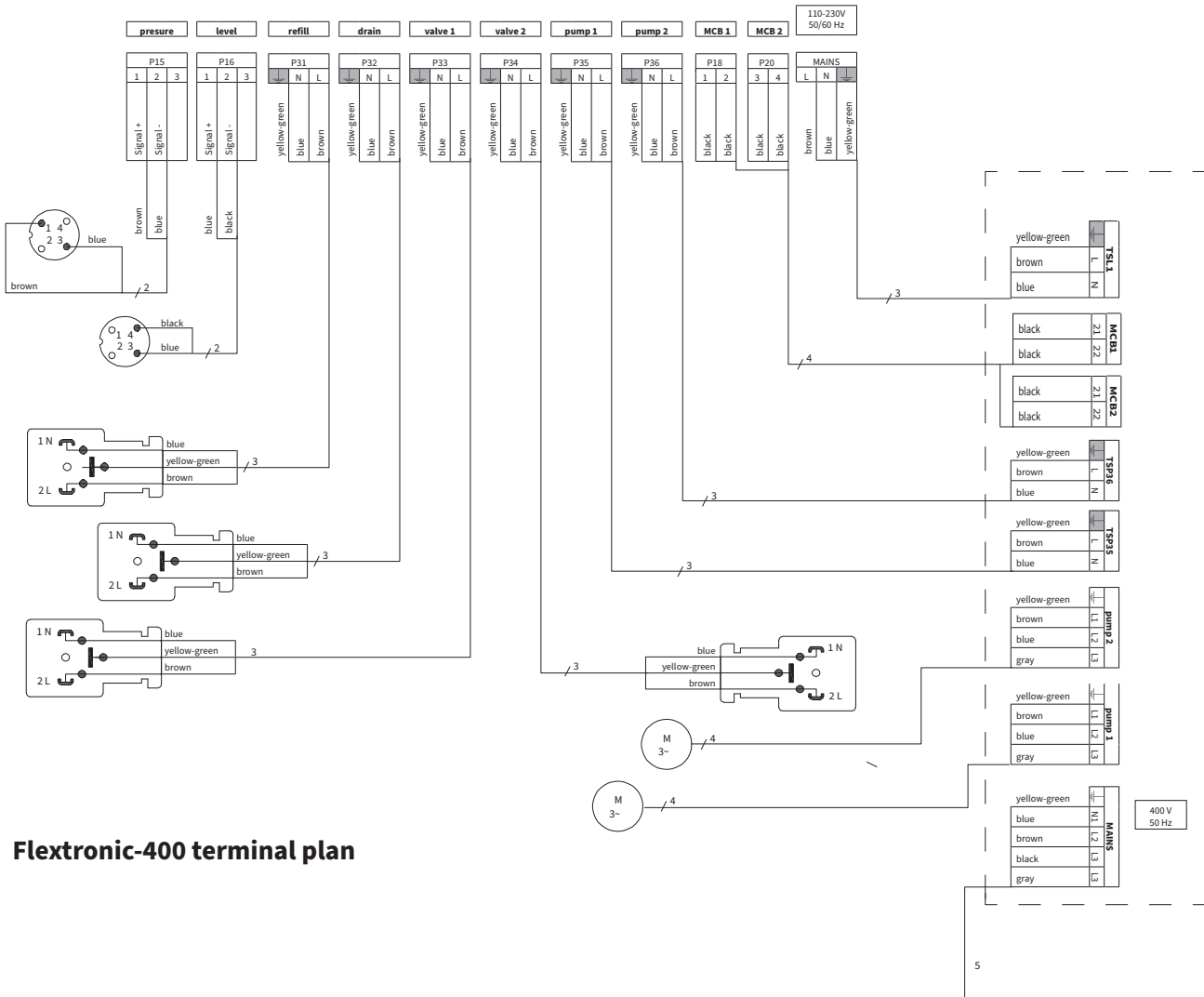
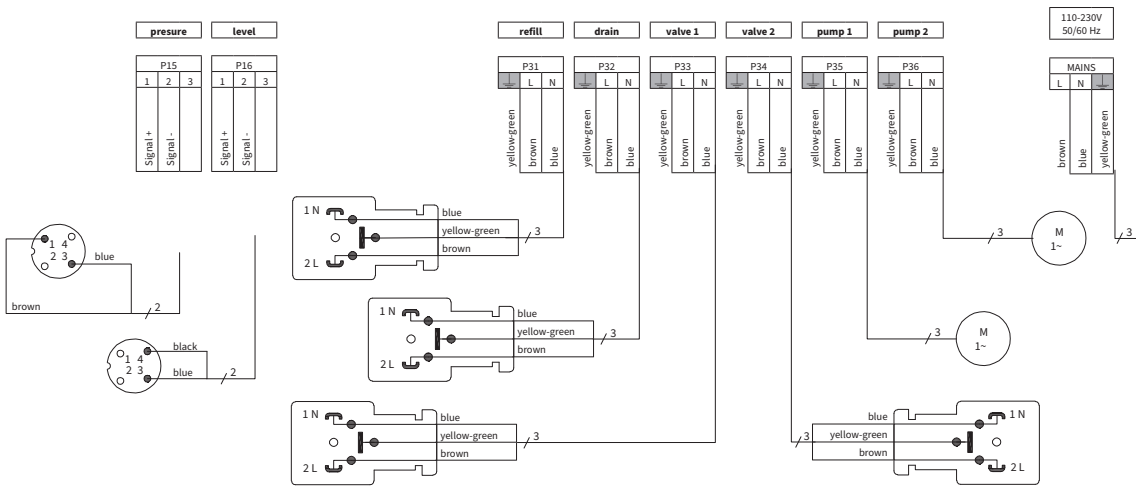

## Flextronic-400 terminal plan

## EU Declaration of Conformity

Manufacturer	Flamco BV Amersfoortseweg 9, 3750 GM Bunschoten, the Netherlands
Product description	Expansion automat
Product type	Flamcomat

This declaration of conformity is issued under the sole responsibility of the manufacturer.  
The object of the declaration described above is in conformity with the relevant Union harmonisation legislation:

Machinery Directive  
2006/42/EC

Pressure Equipment Directive  
2014/68/EU

Low Voltage Directive  
2014/35/EU

EMC Directive  
2014/30/EU

The conformity of the product described above with the provisions of the applied Directive(s) is demonstrated by compliance with the following Standards / regulations:

EN 61000-6-2

EN 61000-6-3 EN

13831 / AD 2000

Bunschoten, 07.10.2016

Signed for and on behalf of:

FLAMCO BV



M. van de Veen  
Managing director

## Contact

### The Netherlands

Flamco Group  
+31 33 299 75 00  
info@flamcogroup.com  
www.flamcogroup.com

### Belgium

Flamco BeLux  
+32 50 31 67 16  
info@flamco.be

### Denmark

Flamco Denmark  
+45 44 94 02 07  
info@flamco.dk

### France

Flamco s.a.r.l.  
+33 1 342 191 91  
info@flamco.fr

### Hungary

Flamco Kft  
+36 23 880981  
info@flamco.hu

### Russian Federation

ООО „Майбес РУС“  
+7 495 727 20 26  
moscow@meibes.ru

### Switzerland

Flamco AG  
+41 41 854 30 50  
info@flamco.ch

### China

Flamco Heating Accessories  
(Changshu) Ltd, Co.  
+86 512 528 417 31  
yecho@flamco.com.cn

### Estonia

Flamco Baltic  
+372 568 838 38  
info@flamco.ee

### Germany

Meibes System-Technik GmbH  
+49 342 927 130  
info@meibes.com

### Italy

Flamco Italy  
+39 030 258 6005  
flamco-italia@flamcogroup.com

### Slovakia

Flamco SK s.r.o.  
+421 475 634 043  
info@meibes.sk

### United Arab Emirates

Flamco Middle East  
+971 4 8819540  
info@flamco-gulf.com

### Czech Republic

Flamco CZ s.r.o.  
+420 284 00 10 81  
info@meibes.cz

### Finland

Flamco Finland  
+358 10 320 99 90  
info@flamco.fi

### Germany

Flamco GmbH  
+49 2104 80006 20  
info@flamco.de

### Poland

Flamco Meibes Sp. z o.o.  
+48 65 529 49 89  
info@flamco.pl

### Sweden

Flamco Sverige  
+46 50 042 89 95  
vvs@flamco.se

### United Kingdom

Flamco Limited  
+44 17 447 447 44  
info@flamco.co.uk

**Flamco B.V.**  
Amersfoortseweg 9  
3751 LJ Bunschoten  
the Netherlands  
+31 33 299 75 00  
info@flamco.nl  
[www.flamcogroup.com](http://www.flamcogroup.com)

Copyright Flamco B.V., Bunschoten, the Netherlands. No part of this publication may be reproduced or published in any way without explicit permission and mention of the source. The data listed are solely applicable to Flamco products. Flamco B.V. shall accept no liability whatsoever for incorrect use, application or interpretation of the technical information. Flamco B.V. reserves the right to make technical alterations.

Man\_Flamcomat-Starter\_C4\_eng\_2020-11